

Integrated Pollution Prevention and Control (IPPC)

DRAFT

Horizontal Guidance for Odour Part 2 – Assessment and Control



**ENVIRONMENT
AGENCY**



Preliminary Pages

Commissioning Organisation
Environment Agency
Rio House
Waterside Drive
Aztec West
Almondsbury
Bristol BS32 4UD

Tel 01454 624400 Fax 01454 624409

© Environment Agency

First Published October 2002

ISBN xxxxxxxxxxxxxxxxxxxxxxxx

Applications for reproduction should be made in writing to:

Liz Greenland
Environment Agency
Scientific and Technical Information Service
2440 The Quadrant
Aztec West
Almondsbury
Bristol
BS32 4AQ

All rights reserved. No part of this document may be reproduced, stored in a retrieval system, or transmitted, in any form or by any means, electronic, mechanical, photocopying, recording or otherwise, without the prior permission of the Environment Agency.

Record of changes

Version	Date	Change
1	October 2002	Initial issue as a working draft for consultation

Note:

Queries about the content of this consultation document should be made to the author, Lorraine Powell at lorraine.powell@environment-agency.gov.uk or sent in writing please to the address below.

Written comments or suggested improvements submitted in response to the consultation exercise should be sent to Mark Cairns at mark.cairns@environment-agency.gov.uk or at:

Environment Agency
Block 1
Government Buildings
Burghill Road
Westbury-on-Trym
Bristol.
BS10 6BF

Introduction

This guidance has been produced by the Environment Agency for England and Wales in collaboration with the Scottish Environment Protection Agency (SEPA) and the Northern Ireland Environment and Heritage Service (NIEHS). Together these are referred to as “the Agency” or “the Regulator” in this document.

This document has been released in the form of a working draft. Publication in final form will take place after wider consultation with industry, government departments, non-governmental organisations and other interested parties. Comments on this document and proposals for improved ways of working are particularly welcome during the consultation period.

The field of odour measurement and control is very wide in scope and is continually developing. There are a number of areas where it would be desirable to have more data than is currently available, however this has been balanced against the need to provide guidance at this time. The best information available to the Agency has been used in compiling this document. Any additional data which is supplied to the Agency as part of this consultation which is constructive and relevant to the content and purpose of this guidance note will be most welcome and will be considered in the post-consultation review.

The scope of this guidance

In England and Wales the Environment Agency will have regulatory responsibility for IPPC installations designated as A1 and Local Authorities will have responsibility for A2 activities. In Scotland and Northern Ireland there is no distinction between A1 and A2 activities. Therefore SEPA will regulate all Part A installations in Scotland and NIEHS will regulate all Part A installations in Northern Ireland. In both England & Wales and in Scotland legislation is in place to implement IPPC. In Northern Ireland the relevant legislation is in preparation and any queries should be directed to EHS.

In England and Wales guidance relating to odorous emissions from Part A2 and Part B activities can be found in the relevant Secretary of State’s process guidance notes or IPPC/PPC sector guidance notes.

Guidance on odour control requirements which are specific to the waste management licensing regime can be found in [Reference 9](#). As an interim measure, the aforementioned reference should also be consulted with respect to those landfill operations which will be migrating to IPPC or PPC.

The H4 Guidance Note consists of two parts:

Part 1 - outlines the main considerations relating to the **Permitting and Regulation** of odour-generating activities. It is aimed primarily at the information needs of Regulators, but also contains information which will be of use to Applicants ([see Reference 1](#)). The Note:

- Describes the information relating to odorous releases that is required from the Operator for the purpose of making an Application for a Permit;
- Describes the process of determination as it relates to odour;
- Provides background information relating to the human response to odours; and
- Outlines the tools available for the assessment of the environmental impact of odour.

Part 2, - “**Assessment & Control**” – this document – is aimed equally at Regulators and Operators. It describes:

- A range of odour impact methodologies;
- The collection of odour samples;
- The “measurement” of odour – using analytical and sensory techniques;
- The control of odour by design, and by operational and management techniques; and
- The range of “end-of-pipe” odour abatement technologies available.

Part 2 provides background information in support of Part 1 and will assist in determining BAT for a given installation.

The Horizontal odour guidance - Parts 1 and 2 – provide an overview of the subject and should be used in conjunction with the appropriate Sector Guidance Note to determine BAT for a specific installation, taking local factors into account.

Table of Contents

1	ASSESSING THE IMPACT OF ODOUR	1
1.1	Overview – what type of assessment?	1
1.2	Assessment based on process (emission) measurement.....	3
1.2.1	Dispersion modelling	3
1.2.2	Radius of effect (Warren Spring dmax equation).....	3
1.2.3	Use of emission factors	4
1.3	Assessment where emissions cannot be measured at source	6
1.3.1	Relating to receptors – assessment of community exposure.....	6
1.3.2	Odour mapping.....	9
1.4	Inventory of materials and odour sources	11
1.5	Odour impact assessment reporting	15
1.5.1	Overview.....	15
1.5.2	What should a report cover?.....	15
2	MEASURING ODOURS	18
2.1	Practical considerations	18
2.2	Overview of methods	19
2.3	Analytical (chemical) techniques.....	20
2.4	Sensory assessment	24
2.5	Summary: comparison of chemical vs sensory assessment techniques	27
2.6	Other means of quantifying emissions.....	28
2.6.1	Use of mass balance data	28
3	SAMPLE COLLECTION	29
3.1	Source characteristics	29
3.1.1	Point sources and area sources	29
3.1.2	Variability	29
3.2	Sampling of odour emissions.....	30
3.2.1	General considerations.....	30
3.2.2	Sampling location	30
3.2.3	The number of samples required	31
3.2.4	Sampling duration.....	31
3.2.5	Sample collection procedures and equipment	31
3.2.6	Sample life.....	36
3.2.7	Limits of detection and uncertainty	36
4	PRINCIPLES OF PREVENTION & REDUCTION	37
4.1	Preventing and reducing emissions	37
4.1.1	Odour dilution as a means of control	38
4.1.2	Separation distances/buffer zones	39
4.1.3	Landscaping (tree planting and earth banking).....	39
4.1.4	Dispersion.....	39
4.1.5	Other techniques	40
4.1.6	Containment	40
4.2	Abatement techniques (“end-of-pipe” techniques).....	43
4.2.1	General.....	43
4.2.2	Criteria to consider in the choice of technique	43
4.2.3	Overview of main abatement techniques.....	46
4.2.4	Adsorption	47
4.2.5	Dry chemical scrubbing	51
4.2.6	Biological techniques	52
4.2.7	Absorption (scrubbing).....	58
4.2.8	Incineration	65
4.2.9	Other techniques	70
	REFERENCES	74
	GLOSSARY OF ODOUR-RELATED TERMS	75
	APPENDIX 1 - COMPARISON OF MAIN ODOUR ABATEMENT TECHNOLOGIES	77

List of Figures

Figure 1.1: dmax for a range of emission rates 4
Figure 2.1: Olfactometric testing in the laboratory 25
Figure 2.2: Schematic of an olfactometer 25
Figure 2.3: process inputs and outputs for a solvent process 28
Figure 3.1: Sampling a point source 29
Figure 3.2: Sampling odours from an effluent treatment plant 29
Figure 3.3: Odour sampling apparatus 32
Figure 3.4: Schematic of sampling equipment 32
Figure 3.5: Dilution apparatus 33
Figure 3.6: Empty sampling bags 33
Figure 3.7: Schematic of equipment for collecting a sample where there is a gas flow. 34
Figure 3.8: Sampling from a biofilter 34
Figure 3.9: Equipment used for sampling from liquid and solid sources where there is no flow 34
Figure 3.10: Air flow through a Lindvall sampling hood 35
Figure 3.11: Demonstration of a sampling train using a sampling hood 35
Figure 3.12: Obtaining a representative odour sample from a liquid 35
Figure 3.13: Confidence intervals for replicated measurements using dynamic
 olfactometry according to EN13725 36
Figure 4.1: Examples of enclosures and exhaust systems for odour 41
Figure 4.2: Generic guidance for the application of different abatement techniques as a function of
 flowrate and concentration 46
Figure 4.3: Schematic diagram of a biofilter 54
Figure 4.4: Schematic diagram of a catalytic incinerator 68
Figure 4.5: Schematic diagram of a plasma unit 72
Figure 4.6: Ozone exhaust odour control system 73

List of Tables

Table 2.1: Characteristics of the odour quantification methods considered 27
Table 4.1: Relative adsorptivity on activated carbon 48
Table 4.2: Comparison of different adsorbent systems 49
Table 4.3: Summary of advantages and disadvantages associated with adsorptive techniques 50
Table 4.4: Summary of advantages and disadvantages associated with dry scrubbing techniques 51
Table 4.5: Summary of advantages and disadvantages associated with biological techniques 57
Table 4.6: Some commonly-used reagents 59
Table 4.7: Summary of suitable absorption medium for different pollutants common odorant species 60
Table 4.8: Summary of advantages and disadvantages associated with absorptive techniques 64
Table 4.9: Summary of advantages and disadvantages associated with incineration 69
Table A1.1: Summary and comparison of abatement technologies 77
Table A1.2: Description of the five generic emission scenarios considered 79
Table A1.3: Comparison of capital costs 79

Picture Acknowledgements:

Figures: 3.1, 3.2, 3.3, 3.6, 3.11 and 4.1 used with permission of AEA Technology Environment.

Figures: 2.1, 3.5 and 3.8 used with permission of OdourNet UK Ltd.

ASSESSING THE IMPACT OF ODOUR	MEASURING ODOURS	SAMPLE COLLECTION	PRINCIPLES OF PREVENTION & REDUCTION	
Overview	Process (emission) based assessments	Assessment where emissions cannot be measured	Inventory of materials and odour sources	Odour impact assessment reporting

1 Assessing the Impact of Odour

Sources of information on odour impact assessment.

Part 1 of this Guidance Note ([Reference 1](#)) gives a broad overview of odour impact assessment as required for an Application for an IPPC Permit, or for determining a “baseline”.

It describes the type of situations when an assessment might be required, and what types of assessment might be suitable in different circumstances. (Section 2.4(2) and Appendix 3 of Part 1).

IPPC Guidance Note H1: Environmental Assessment and Appraisal of BAT ([Reference 8](#)) covers:

- Screening out of those installations which are of sufficiently low risk (from an odour point of view) to warrant no further information on odour;
- Screening out of insignificant sources on an installation which poses some risk to sensitive receptors (this Guidance Note will provide the information to assess those sources which are not screened out by H1); and
- A methodology to compare different proposed abatement options (which may be to abate odour, or for a wider purpose) in terms of their total environmental impact, ie looking at issues such as energy use, wastes generated, water or other raw material usage and costs etc.

In this note, this Section considers:

- a number of the tools used for odour impact assessment in more detail; and
- the type and coverage of information that should be provided in a typical odour impact report.

Odour Management at IPPC Intensive Livestock Installations ([Reference 5](#)) describes the odour impact assessment requirements for pig and poultry units and describes the tools available for different circumstances.

Guidance for the Regulation of Odour at Waste Management Facilities under the Waste Management Licensing Regulations ([Reference 9](#)) describes requirements for landfill and transfer stations. As an interim measure, until sector specific IPPC/PPC guidance is available for this sector, this waste management licensing guidance should also be used for IPPC/PPC landfill operations.

1.1 Overview – what type of assessment?

The aims of an odour impact assessment.

The aim of an odour impact assessment will be some or all of the following:

- to predict the exposure of sensitive receptors to odour and to apply a test of acceptability in some form (acceptability and exposure standards are described in Part 1 of this guidance note – [Reference 1](#)). This could relate to new or existing plant
- to indicate the amount of abatement (or additional abatement) required
- to look at trends – improvement or worsening performance over a period of time
- to determine compliance with a Permit condition, and
- investigating complaints.

There may also be a need to compare the impact or acceptability of different odour abatement options (options appraisal). This process is described in IPPC Guidance Note H1 ([Reference 8](#)).

How much detail is required?

In the simplest of cases an odour impact assessment will consist of a qualitative estimation of the risk - is it likely to cause a problem, or isn't it? Have there ever been any complaints? Is it possible to detect the odour outside of the installation boundary in areas which may be frequented by people?

This will usually be sufficient where the risk of causing annoyance is low, provided that a simple justification of the factors considered and the outcome is provided.

As the risk of causing annoyance increases, and the costs of taking corrective action increase and/or a history of odour complaints or annoyance already exists, then so will the need for a more in-depth assessment that takes a more quantitative approach.

ASSESSING THE IMPACT OF ODOUR	MEASURING ODOURS	SAMPLE COLLECTION	PRINCIPLES OF PREVENTION & REDUCTION
Overview	Process (emission) based assessments	Assessment where emissions cannot be measured	Inventory of materials and odour sources Odour impact assessment reporting

Where an existing installation has a history of odour complaints and obvious problems, a detailed odour assessment as part of the application will usually be required.

It is important, in terms of cost, effort and the need for a useful output, to match the most appropriate form of assessment to the objectives and purpose of carrying it out in the first place.

If odour impact has never been systematically assessed before, the starting point should be a simple walk over survey of the installation during normal operations. A simple screening assessment should provide a clear indication of whether any potentially significant odour sources exist and whether further more detailed assessment is required. The “worst case” should also be considered - under what operating conditions are odour emissions worst? Meteorological conditions can also affect odour exposure at receptors and it is useful to walk around beyond the installation boundary under the most adverse conditions - light winds / stable conditions - to see if odour is detectable.

What method should be used?

Odour impact methodologies can be broadly classified into two main “types” based upon whether emissions at source can be measured or estimated or, where this information is not available, the effect at receptors has to be assessed:

(i) *Process (emission)-based Assessments*

- Monitoring and Predictive Modelling Assessments:
These estimate the “footprint” of effect of the activity by mathematical modelling of actual or estimated/predicted emissions:
 - simple “indicative” models, e.g. Warren Spring d_{max} , Schauburger & Piringer (for livestock).
 - mathematical atmospheric dispersion modelling.

(ii) *Assessments based upon measurements around the source and/or conditions in the community (where measurement of emissions at source is not feasible)*

- Community-based Assessments:
those that use information collected at the receptor(s), based on the opinions and judgement of those exposed, to estimate the extent of the footprint and the magnitude of the exposure. There are two sub-sets:
 - assessment of community response
complaint histories (based on past and present experiences)
attitude surveys (based on past exposures)
population panels (on-going assessment of the current situation)
 - assessing the extent and magnitude of the exposure in the community
field judges/panels
- Odour mapping

These assessment methods are described in more detail in [Sections 1.2](#) and [1.3](#).

A third form of assessment is to undertake a thorough review of materials used and generated, products, wastes and release points. This is described in [Section 1.4](#).

Within each category there are methods ranging from the simplistic to more detailed, and the cost is generally proportional to the level of detail (in addition to the scale of the assessment). Where issues are more complex it is often appropriate to undertake a simple assessment as a “scoping” study in order to direct and prioritise detailed effort more cost-effectively.

Protocols and reporting

It is important to ensure that all relevant factors have been taken into account, worst case emissions have been considered (if relevant) and appropriate assumptions made. Assessment reports should contain sufficient raw data, description of the methodology used and justification for the assumptions made, to allow the Operator and Regulator to have confidence in the outcomes.

[Section 1.5](#) outlines the protocols for undertaking an assessment and for reporting.

ASSESSING THE IMPACT OF ODOUR	MEASURING ODOURS	SAMPLE COLLECTION	PRINCIPLES OF PREVENTION & REDUCTION	
Overview	Process (emission) based assessments	Assessment where emissions cannot be measured	Inventory of materials and odour sources	Odour impact assessment reporting

1.2 Assessment based on process (emission) measurement

Emissions can be measured or predicted by:

- collecting and analysing odour samples
- using emission factors (limited application at present)
- using mass balance data
- comparison to a similar operation.

Collection of samples for odour analysis is described in [Section 3](#).

The numerical data obtained can be used in the following ways:

1.2.1 Dispersion modelling

Where the odour emission rate from a source is known by measurement, or can be estimated, the odour concentration in the vicinity can be predicted by means of dispersion modelling.

A dispersion model attempts to describe the effects of atmospheric turbulence on the emission(s) as they undergo dilution and dispersion in the surrounding environment. Concentration is *one* of the factors that determine the impact of a given odour on sensitive receptors.

The modelling of odour is still a developing field when compared to other pollutants. A range of different models have been used for odour modelling and have a number of common features, but there are differences in the way that data is dealt with between the older gaussian models and the new generation models such as AERMOD and ADMS.

To visualise the extent of odour impact it is useful to produce contour plots showing odour concentrations around the source or highlighting where concentrations exceed the appropriate exposure benchmark which relates to acceptability.

Appendix 4 in Part 1 of this document ([Reference 1](#)) covers the subject in more detail and proposes a “recommended” approach to odour modelling aimed at bringing about consistency of approach. There may be circumstances in which there is a valid reason for taking a different approach and the proposed parameters do not exclude this, provided that the methodology is described and justification given.

“Benchmarks” are described in Appendices 5 and 6 of part 1 to this Note ([Reference 1](#)).

1.2.2 Radius of effect (Warren Spring dmax equation)

This is a simple scoping study **that should be used with caution**. It can, however, be a good indicator of the need, or otherwise, for more detailed study. However it is vital that the “health warnings” given below should be noted when interpreting the output from this equation. More detailed information on how this was derived and its limitations can be found in Section 11.4.4 of the Concise Guide ([Reference 3](#)).

When considering the impact of an actual or potential odour-emitting source it can be useful to make a rough estimate of how far away from the odour source the local population must reside so as not to experience annoyance, i.e. the radius of effect of the source with respect to annoyance potential.

The “d max” equation is based upon work carried out by Warren Spring Laboratory ([Reference 3](#)). The model predicts distance dmax (maximum distance for complaints) in metres at which complaints are expected as a function of the rate of odour emission, E, in odour units per second:

$$d \text{ max} = (2.2E)^{0.6}$$

This is shown graphically overleaf for a range of odour emission rates.

ASSESSING THE IMPACT OF ODOUR	MEASURING ODOURS	SAMPLE COLLECTION	PRINCIPLES OF PREVENTION & REDUCTION	
Overview	Process (emission) based assessments	Assessment where emissions cannot be measured	Inventory of materials and odour sources	Odour impact assessment reporting

Health warnings:

- 2.2 is a constant. Its range is however, from 0.7 to 7; 2.2 is the best estimate. The lower limit (A = 0.7) provides an effective lower estimate of complaint distances. Similarly, the upper limit (A = 7) provides an effective upper estimate of complaint distances. The confidence limits are therefore very wide.
- Most of the data used to derive the correlation referred to emissions effectively at ground level. Where dmax is at least 40 times the effective chimney height from the point of emission, the emissions could be treated as ground level sources at these distances. Therefore the result will be invalid unless dmax is at least 40 times the effective chimney height.
- The range of application should normally be limited to emission rates in excess of 500ou s⁻¹.

NOTE that use of this equation will not fulfil the needs of a detailed odour impact assessment, either for an existing installation or for a new installation. Part 1 of this guidance note (Reference 1) shows where it might be suitable for use.

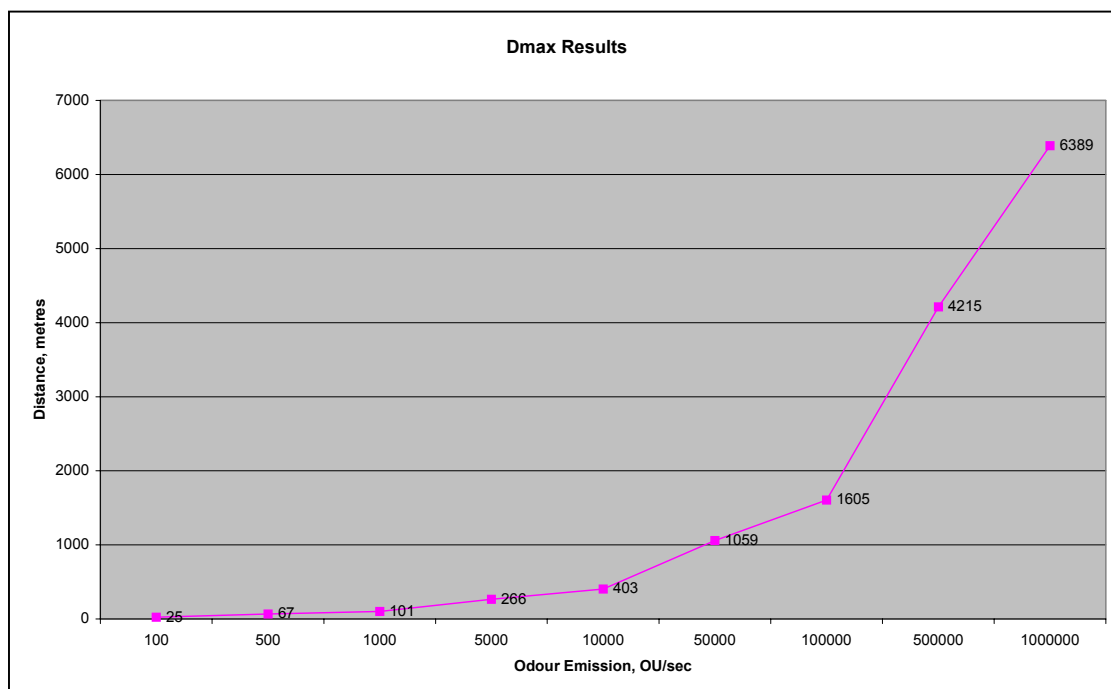

Figure 1.1: dmax for a range of emission rates.

1.2.3 Use of emission factors

Odour emission factors have been derived for only a limited range of activities. These are based upon sampling and subsequent assessment by olfactometry to give an odour emission rate per source unit. For example, to calculate the odour emissions from an intensive poultry operation the following calculation is typically used:

$$\text{Odour emission rate} = \text{Emission rate per bird (ou/s/bird)} \times \text{Number of birds}$$

Different emission rates are available for birds as the age (and odour emission) increases.

The odour emission rate can be used to predict the impact at receptors by:

- applying the dmax equation to estimate the maximum distance for complaints
- using the Schauburger and Piringer methodology to assess the protection distance to avoid annoyance, which takes some account of local conditions (Reference 10)

ASSESSING THE IMPACT OF ODOUR	MEASURING ODOURS	SAMPLE COLLECTION	PRINCIPLES OF PREVENTION & REDUCTION	
Overview	Process (emission) based assessments	Assessment where emissions cannot be measured	Inventory of materials and odour sources	Odour impact assessment reporting

- using a mathematical dispersion model.

The use of the Schauburger & Piringer equation is described in the Agency IPPC Guidance “Odour management at livestock installations” ([Reference 5](#)).

Dmax and Schauburger & Piringer are only scoping methodologies. A more detailed assessment would normally be required where there is risk of odour impact on sensitive receptors. [Reference 5](#) describes the circumstances under which a detailed assessment would be required.

Outside of the intensive livestock industry few emission factors are available. However, it may be possible to derive factors for application to a similar situation, e.g. for predicting the impact of an operation still at the planning stage. There must be sufficient justification however to show that these are representative of the operation to which they are applied.

ASSESSING THE IMPACT OF ODOUR		MEASURING ODOURS	SAMPLE COLLECTION	PRINCIPLES OF PREVENTION & REDUCTION	
Overview	Process (emission) based assessments	Assessment where emissions cannot be measured		Inventory of materials and odour sources	Odour impact assessment reporting

1.3 Assessment where emissions cannot be measured at source

In some cases it will not be possible to measure or to predict emissions at the source in any meaningful way. The emission points may not be well defined – for example there may be a number of fugitive release points, or the emission rate may vary a lot from day to day or hour to hour. It is possible to measure the emission from area sources, but only if the surface is homogeneous.

In such cases an assessment may be based upon:

- the reaction of the people exposed to the odour emission (see Section 1.3.1).

Or, where emissions are not too variable:

- measurements taken in a pattern around the source - odour mapping (see Section 1.3.2)

1.3.1 Relating to receptors – assessment of community exposure

Purpose of assessment and appropriate choice of protocol

There are a number of situations where an assessment of the community exposure or response might be required:

- to substantiate complaints or identify/confirm a source
- to provide a correlation between community response and certain processes or activities
- to determine the extent of the area, the “footprint”, over which an odour problem is occurring.

Assessment of the extent of community exposure can be approached in two ways:

- by gauging the magnitude of the community *response*:
 - complaint records (which are based on past and current experiences)
 - public attitude surveys (based on past exposures)
 - population panels & odour diaries (on-going assessment of current situation).
- by assessing the magnitude of the *exposure*:
 - analysis of ambient air samples (not discussed here, see [Section 3.2.2](#))
 - using field panel tests or field judges.

To collect meaningful information relating to what is generally a very subjective issue, and to separate out the perceived issues from the actual problems, recognised and standardised objective procedures should be used as far as possible. A number of specific investigative techniques and methods have been documented and some countries such as Germany and the Netherlands have been particularly active but *standardised* procedures have been slow to develop. This section briefly describes some of the available options and where they might be used.

The following field assessment methodologies have been produced in Germany by VDI and roughly equate to British Standards in their purpose and approach.

- VDI 3883 Part 1 Effects and Assessment of Odours; measurement of nuisance through interview; questionnaire technique.
- VDI 3883 Part 2 Effects and Assessment of Odours: determination of annoyance parameters by questioning. Repeated brief questioning of neighbour panellists.
- VDI 3940 Determination of odorants in ambient air by field inspection.

The VDI standards have been used quite widely in Germany and the Netherlands and are finding increasing use in other countries.

ASSESSING THE IMPACT OF ODOUR		MEASURING ODOURS	SAMPLE COLLECTION	PRINCIPLES OF PREVENTION & REDUCTION	
Overview	Process (emission) based assessments	Assessment where emissions cannot be measured		Inventory of materials and odour sources	Odour impact assessment reporting

Assessing the magnitude of community response

Complaint records:

Odour complaints are widely used as indicators of the existence of an odour problem and the severity of the problem. However, it is not certain how accurately the number of odour-related complaints accurately reflects the general level of annoyance in the community and how complaints can best be used in support of an investigation.

Complaints are a good indicator of an incident such as an accidental release or the sudden onset of a new source of annoyance. The resulting complaints can be used for investigative purposes; to identify the source and to map out the extent of the affected area (possibly using dmax), from which some estimate of the odour emission rate can be made.

Such records do not however provide an ongoing picture of the general underlying level of dissatisfaction, neither is it sufficient to rely on the number of complaints alone to act as an indicator of regulatory compliance. A reduction in the number of complaints can, over a period of time (which will allow meteorological variation to be taken into account), demonstrate that there has been an improvement following changes to a process or installation of abatement equipment. A reduction in complaints may, however, occur because people get used to the odour, or get fed up with lack of improvement and do not bother to report any more.

In order to maximise the benefit of a complaint record, good quality data are essential. Whilst there is no standard methodology for collecting complaint data, it is suggested that the following should be recorded:

- location where odour was detected
- date
- time
- duration (or frequency of recurrence)
- a description of the odour – what does it smell like
- weather conditions at the time, particularly wind direction
- a description of any visible activity occurring at the time.

Where possible it is often useful to not only record odour incidents, but also record odour impact at regular intervals during the day. This is likely to record many occasions of “no odour”, but can provide a very useful data set for identification of sources when analysed along with wind direction data. This is the basis of an “odour diary” described later in this section.

Whilst differentiation may not be an issue, in a locality with a number of potential sources it is helpful to be able to characterise the odour, i.e. “it smells like...”, rather than “it smells horrible”. Section 3 of Part 1 to this Note describes complaint investigation in more detail and a list of published descriptions for common odorants is given in Appendix 10 of that Note ([Reference 1](#)).

Attitude surveys (public opinion surveys) - measuring the degree of annoyance

This form of survey involves interviewing *on a single occasion* a selected sample of the population about their past experiences. Interviews can be conducted in person, by telephone or by questionnaire designed to conceal the primary interest in odour-related annoyance. This form of questioning, together with modelling of odour emissions, forms the basis of the dose-effect studies described in Part 1 of this Guidance Note.

The survey must be designed and the results interpreted by specialists to avoid inadvertent bias and to give a representative picture a sufficiently large sample must be recruited. The cost will therefore be relatively high, although it will give an installation-specific confirmation of whether emissions lie within the band of acceptability for that particular population. It must also be remembered that the record will comprise a cumulative perception and individual incidents will probably be lost, as will any variation in the level of annoyance over time. However, if executed effectively it will give a more unbiased picture than if relying on complaints alone.

The methodology is set out in VDI 3883, Part 1 ([Reference 16](#)).

ASSESSING THE IMPACT OF ODOUR		MEASURING ODOURS	SAMPLE COLLECTION	PRINCIPLES OF PREVENTION & REDUCTION	
Overview	Process (emission) based assessments	Assessment where emissions cannot be measured		Inventory of materials and odour sources	Odour impact assessment reporting

Assessing the magnitude of community response (cont)

Population panels - measuring the frequency of annoyance

These differ from opinion surveys in that the views of the same group are repeatedly obtained over a period of time. The methodology is set out in VDI 3883, Part 2 ([Reference 16](#)).

Panels can be made up in different ways depending on the purpose of the survey. The most common arrangement is for a large group of volunteers selected at random from a particular area to indicate at regular predetermined intervals, generally weekly by pre-paid postcard or phone, whether they detect and are annoyed or offended by odour. The location of the observation would usually be outside the home. Around 25 -35 responses are needed, although some tests have been conducted with as few as 10 -15 persons. This form of information gathering has the advantage that a relatively large number of people can be consulted and it does not rely on past memory of an experience.

Odour diaries are a form of population panel. Data is gathered from the same sample of people over a period of time. Participants may be instructed to record information every day, every time they detect an odour or every time they detect an "offensive" odour over a specified period of time, although there is likely to be communication with and exchange of information between the participants and the organiser during this time. Diarists may be asked to record - time, date, frequency of occurrence, duration, offensiveness (and perhaps character) strength, prevailing weather conditions - in effect, the same as for a complaint.

The process Operator would need to log process operations and relevant parameters over the same period to allow correlation.

Assessing the extent and magnitude of exposure

Use of field panels or field judges - determination of the area affected

Teams of observers are recruited to undertake subjective field assessments on one or more occasions to determine the extent of the affected area around or downwind of a source, or to assist in locating a source by working upwind.

This has been used as an alternative to the collection of ambient air samples. Although the use of trained observers is preferred, such testing can be undertaken with untrained groups following basic instruction, although repeat testing may be needed on more than one occasion to get the same level of result. If observations are taken by a group of dispersed observers at the same time and using the same scoring system then odour maps can be constructed with isopleths enclosing areas of equal intensity. To date there are only a limited number of examples where these techniques have been used.

The methodology is set out in VDI 3940.

As an alternative, a variation of the olfactometric "sniff-testing" technique described in [Section 2.4](#) and also, in more detail, in Appendix 8 of Part 1 to this document ([Reference 1](#)) can be used. A single judge, who might be a regulatory officer, drives around the source and carries out an assessment at a number of locations, possibly predefined. This can be undertaken at different times on the same day or on different days at the same time. The type of information which should be recorded is given in Appendix 8 of Part 1.

Commonly used questioning regimes

It is important to use an appropriate questioning regime in order to collect relevant information and to allow for repeatability between different surveys. Sometimes it is relevant to disguise the purpose of a survey to avoid bias (as described in VDI 3883). The latter should be designed and administered by professional market researchers.

- For the purpose of keeping odour diaries or similar a less onerous questioning regime is usually appropriate. To establish short term attitudes local people can be asked to rank the odour by:

ASSESSING THE IMPACT OF ODOUR		MEASURING ODOURS	SAMPLE COLLECTION	PRINCIPLES OF PREVENTION & REDUCTION	
Overview	Process (emission) based assessments	Assessment where emissions cannot be measured		Inventory of materials and odour sources	Odour impact assessment reporting

Category	Annoyance level
0	No odour
1	Not annoying
2	Slightly annoying
3	Annoying
4	Very annoying
5	Extremely annoying

- To monitor short term events it may be appropriate to just enquire whether odour is present or not. – a simple yes/no

1.3.2 Odour mapping

This method of assessment is not based on source measurements, but upon measurements of a single compound taken on a grid pattern over a defined area using a portable direct reading instrument.

A computer model is used to draw contour plots around the source(s), representing the pattern of concentration measured across the grid.

This can be used for the following.

- Investigating sources in terms of their relative contribution to the total odour from the installation. At a distance, if it is measurable, the odour concentration measured is representative of the total odour from the installation. Closer in, the distribution breaks up across the grid pattern and centres upon the sources with the highest emission.
- Looking at trends/changes in odour distribution under different conditions of weather and operating parameters.
- Predicting the impact on receptors as a crude indicator.
(The odour contours derived by this method cannot be compared with those derived from a dispersion model for the purposes of comparison with the odour exposure criteria described in Appendix 6 of Part 1 of this Note ([Reference 1](#)) as the latter relate to long term acceptability. They can however be compared with the odour threshold and multiples thereof as described in Appendix 1 of [Reference 1](#).)

This technique can be useful where there are a number of sources across an installation, possibly a combination of area, point and fugitive sources. Some may have a known flow rate associated with them and some may have unknown or no apparent flow.

Far enough away from the installation, the measurements will represent the total emission of the installation but closer in, and on the installation itself, it should be possible to evaluate the influence of individual sources.

Ideally the concentrations at the grid points should be measured at more or less the same time but, realistically, measurements should be taken over as short a time period as possible, but allowing sufficient time at each point to get a meaningful result.

Where emissions are very variable it may be necessary to carry out a number of such surveys to cover the range of both emission scenarios and also weather conditions.

Outline of procedure:

Select an appropriate substance as a marker; this must be representative of the total mixture. See [Section 2.1](#).

Measurements are taken using a portable instrument in a grid pattern across the installation. Such an instrument must be capable of measuring down to the odour threshold and with a relatively quick response time, good repeatability, and rapid recovery between measurements. Possible interference between compounds (and its relevance) should be considered. Instruments are described in [Section 2.3](#).

ASSESSING THE IMPACT OF ODOUR		MEASURING ODOURS	SAMPLE COLLECTION	PRINCIPLES OF PREVENTION & REDUCTION	
Overview	Process (emission) based assessments	Assessment where emissions cannot be measured		Inventory of materials and odour sources	Odour impact assessment reporting

Weather conditions need to be constant for the duration of the survey work . It may be necessary to undertake more than one survey on different days to cover different wind directions and speeds. Gusting and the eddy effects close to buildings or other topographical features will interfere with the pattern of dispersion. Discharges from a chimney or at a temperature above the prevailing atmospheric temperature may rise and so will not be detectable at ground level but may ground at a point away from the source. Raised areas of ground may also interfere with the pattern of dispersion.

The size of the grid will be a compromise between the number and distribution of sources, the size of the installation and area beyond the boundary which is to be surveyed, and the number of measurements which will be required, and the resolution required. It is usual to take a number of samples at each point and take an average value. The measurement points must be well defined such that the same points can be identified for future survey work. GPS has sometimes been used for this purpose.

This form of assessment has been used on sewage treatment works ([Reference 6](#)) and landfill sites.

ASSESSING THE IMPACT OF ODOUR		MEASURING ODOURS	SAMPLE COLLECTION	PRINCIPLES OF PREVENTION & REDUCTION
Overview	Process (emission) based assessments	Assessment where emissions cannot be measured	Inventory of materials and odour sources	Odour impact assessment reporting

1.4 Inventory of materials and odour sources

This can be undertaken where odour emissions cannot be measured in any meaningful way, possibly because there are many fugitive releases or area sources. To be useful in terms of impact assessment however the outcome needs to be considered alongside the complaint history or a review of community attitudes. Even without the impact aspect, such a survey can be used as a tool to help to identify issues that can be addressed by better management.

In order to identify potentially significant sources of odour a comprehensive audit of all release points and odorous materials should be carried out, and an inventory compiled. Potential sources can be identified on a site map and a simple ranking system can be used in the first instance to prioritise the sources for further investigation.

In outline, this will require the following steps:

- 1. Establish the sources or activities associated with the odour emission, and identify any characteristics:**

Is there a problem and to what extent?

A history of local odour-related complaints will indicate whether offensive odours are detectable beyond the installation boundary. The Operator or Regulator could also carry out periodic subjective testing ("sniff testing") to identify potential problems or to ascertain any pattern to the emissions.

Differentiating between odour emissions arising from neighbouring plants is often relatively easy. However where odorous processes are located close together and the nature of emissions is similar more detailed investigation may be required - community-based subjective assessment and comparison with detailed process logs may be indicated.

"Fingerprinting" of a particular odour may be possible using gas chromatography mass spectroscopy (GC-MS) whereby individual odorous compounds may be identified from a sample of air collected from a particular source. This is described in [Section 2.3](#).

Where the source cannot be clearly identified, or the impact needs to be assessed in more detail, it may be necessary to undertake a more in-depth investigation. The type of assessment and level of detail required are discussed in Part 1 of this note ([Reference 1](#)).

Identify the sources

Once a particular activity has been identified as the origin of odorous emissions, specific sources or emission points should be identified. This can often be accomplished by a systematic "walk-around". Some source(s) may be immediately apparent, but it is important to consider associated release points which may be less obvious - these might be identified by running through process flow diagrams and mass balance data, ie considering all inputs and outputs.

In addition to the primary process or activity, operations to consider may include:

- raw materials, both storage and handling (particularly putrescible materials)
- transfer processes, including unloading of vehicles
- heating and combustion or steam-raising plant
- washing, cleaning and maintenance operations
- the formation of odorous by-products
- waste storage and disposal
- open tanks, lagoons pits and effluent treatment plant
- start-up and shut-down
- emergency releases
- antiquated, inefficient or inadequate odour control plant.

Less obvious sources could include:

- pumps and flanges

ASSESSING THE IMPACT OF ODOUR		MEASURING ODOURS	SAMPLE COLLECTION	PRINCIPLES OF PREVENTION & REDUCTION	
Overview	Process (emission) based assessments	Assessment where emissions cannot be measured	Inventory of materials and odour sources		Odour impact assessment reporting

- leaking vessels or pipes
- ventilation of buildings and storage areas (deliberate and also unintentional - doors left open, holes in the fabric of the building etc.)
- local exhaust ventilation discharge points
- uncovered skips or bins
- storage tank "breathing" vents
- contaminated land
- uncovered vehicles leaving or entering the installation
- contaminated or blocked drains.

It is often possible to reduce or prevent some emissions completely without the need for complex deliberations by taking simple actions such as tightening connections, removing waste, covering odorous materials and repairing leaks.

2. Carry out an odour impact assessment:

The aim of an odour impact assessment is essentially twofold:

- to estimate the impact on the environment of a particular emission (in this case the exposure of sensitive receptors and whether it is likely to cause annoyance)
- to ascertain whether emissions produce an unacceptable impact (which may relate to compliance with a Permit condition, or to a decision relating to the degree of reduction required).

It may be appropriate to undertake a basic scoping study if sufficient numerical data is available (see [Section 1.1](#)) to direct or prioritise more detailed work.

The following information will typically be required for each source to be studied in more depth: (Not all of this will be available for some types of source)

- The identity of the odorous compounds emitted, from chemical analysis, knowledge of the process inputs, outputs and by-products.
- The rate of emission, measured or estimated, (also volumetric flow rate exit temperature and emission height).
- A characterisation of the source - frequency, duration, fluctuation of emission, variation due to season or to processing of different types of material.
- The proximity, direction and sensitivity of receptors, i.e. the local community (on a large installation this may vary considerably for different sources).

And, information relating to all sources on the installation is required.

- The local topography - relative location of valleys, hills, buildings or other features which affect the transport of pollutants between the source and the community.
- Meteorological conditions - a wind rose showing wind frequency from different directions and speed.

At a basic level the sources can be ranked in a number of ways:

- by emission rate
- where a number of sources of different odorants are present, an estimate of relative offensiveness might be used (see Appendix 10 of [Reference 1](#))
- distance from the sensitive receptors, or proximity to the installation boundary – the distance of impact also depends on emission characteristics and weather conditions. (Where there is emissions data for point sources dispersion modelling might be used to give an estimation of the impact. The output from the model can be compared with guideline concentration values)
- an odour source or type with the poorest complaint record

The worst case situation should also be considered in the determination of impact. Operations such as start-up and shut-down, cleaning and maintenance, emergency releases should be considered. There may be an increase in odour emissions during hot weather or when certain types of odorous materials are received or manufactured.

ASSESSING THE IMPACT OF ODOUR		MEASURING ODOURS	SAMPLE COLLECTION	PRINCIPLES OF PREVENTION & REDUCTION
Overview	Process (emission) based assessments	Assessment where emissions cannot be measured	Inventory of materials and odour sources	Odour impact assessment reporting

This will allow sources to be ranked in terms of risk and provides an indication of the relative priority, allowing an action list to be drawn up.

3. Identify a required end-point or desired emission rate for each source and compare options:

The performance required in terms of a reduction in emissions may be determined by regulatory requirements. BAT and the need to avoid causing annoyance in the community may require an improved performance.

Assuming that uncomplicated issues can be addressed directly without recourse to detailed deliberation, then the opportunity for reducing emissions from the remaining sources should be assessed against:

- opportunity for reduction by changes to the way in which the plant is operated - throughput, timing, maintenance, change in materials or process parameters, additional training of operators etc
- better containment - keeping doors and windows shut, repair of buildings, providing automatic roller doors, containment of transfer lines or conveyors, covering or indoors storage of raw materials or wastes
- abatement of malodorous air streams, once contained – both process and ventilation air, by end-of-pipe technologies.

The above techniques are covered in detail later in this Section.

For each option, an assessment of the costs and benefits should be undertaken in order to inform the final selection. Such decisions may not be clear cut and there may have to be a balancing of several factors. IPPC guidance note H1 – Environmental Impact Assessment & BAT Appraisal ([Reference 8](#)) offers a methodology for comparison of abatement options. It is the responsibility of the Operator to obtain the necessary performance guarantees from the manufacturer and/or contractor.

Maintenance and training requirements should also be factored into the decision making process.

4. Identify work that needs to be undertaken and take appropriate action:

Based on the choices made, a timetable of work to be undertaken can be drawn up. It may be appropriate to undertake trials, possibly fairly early in the decision-making process in some cases. These may range from temporary adjustments in operating parameters to installation of pilot plants to test the effectiveness of proposed abatement plant on particular gas streams.

5. Assess effectiveness and re-assess risk of causing annoyance:

Evaluation of the effectiveness of the selected option(s) should again include an assessment of the worst case scenario (and the frequency of occurrence and duration of such events should also be taken into account in the final evaluation).

Where end-of-pipe solutions are used to reduce odorous emissions, the odour abatement efficiency of the odour control plant, and/or the final odour emission rate should be tested on a regular basis. This can be achieved either by direct measurement of odour concentration or by some form of indirect measurement of plant performance. This may be a requirement of the IPPC Permit.

6. Put procedures in place for on-going maintenance and monitoring of performance:

Include maintenance and monitoring requirements in an odour control strategy which covers both short term and long term requirements for the operation as a whole. Structured review periods should be included, together with mechanisms for feedback.

As with any type of process control the ongoing performance should be monitored to ensure that control is maintained at an acceptable level. Where appropriate alarms should be used to alert the operator to failures or malfunctions. Where the odour control strategy includes plant or

ASSESSING THE IMPACT OF ODOUR		MEASURING ODOURS	SAMPLE COLLECTION	PRINCIPLES OF PREVENTION & REDUCTION	
Overview	Process (emission) based assessments	Assessment where emissions cannot be measured	Inventory of materials and odour sources		Odour impact assessment reporting

equipment that becomes progressively exhausted, such as carbon filtration, regular and frequent inspections should be carried out to ensure that an acceptable level of odour control is achieved at all times.

ASSESSING THE IMPACT OF ODOUR		MEASURING ODOURS	SAMPLE COLLECTION	PRINCIPLES OF PREVENTION & REDUCTION
Overview	Process (emission) based assessments	Assessment where emissions cannot be measured	Inventory of materials and odour sources	Odour impact assessment reporting

1.5 Odour impact assessment reporting

1.5.1 Overview

The amount of detail required of any assessment should be proportionate to the risk.

The following is a summary of good practice in terms of reporting protocol and should allow confirmation that the scope and conduct of the work has been competently handled and reflects process variability appropriately.

1.5.2 What should a report cover?

Whilst each assessment will be different and necessarily installation-specific, there are a number of common features which should be covered in a well-planned and executed survey.

Unless the assessment is deliberately targeted at specific events only, or at defined parameters, there will be a need to quantify the emissions in a way which accounts for any cyclical variation as well as any seasonal or day/night changes. The impact, in terms of concentration, of those emissions on receptors will then be predicted by means of dispersion modelling and the outcome interpreted in terms of the likelihood of causing annoyance. It is usual to consider both “normal” operation and also “worst case”. The frequency with which worst case conditions arise is also relevant. In some assessments the odour will be “characterised” in addition to a quantitative assessment (see Part 1 of this note, Appendix 1 – [Reference 1](#)).

New Plant

Where the impact of proposed new plant is being assessed, it will be necessary to describe the location and nature of the proposed operations but obviously there will be no odour history associated with the plant. Emissions data will have to be predicted by comparison with identical or similar operations and/or mass balance data. Justification should be provided for using particular comparative data. Odour impact contours obviously cannot be transferred directly from an existing installation to a proposed one as it relies on modelling emissions using local data from the proposed location.

The report may also make recommendations as to the possible measures that could be taken to achieve BAT, both in terms of housekeeping and other management practices, and options for odour reduction by the addition of end-of-pipe abatement equipment.

In general terms, the aspects which should be addressed during the survey, and reflected in the final report, might be categorised as:

- i) Summary of findings.
- ii) A description of the process or the entire installation, its throughput and location.
- iii) A statement of the objectives of the survey.
- iv) A description of the methodology used for sampling and analysis.
- v) A description of the installation-based work actually undertaken.
- vi) Monitoring results.
- vii) Interpretation of the results and conclusions drawn.
- viii) Recommendations and discussion.

For each aspect, the following would be expected:

i) Summary of findings

Summary of the main issues, conclusions and recommendations.

ii) Process description and “scene-setting”

This should include a description of all aspects of the process which are relevant to the odour issue. The following should be included, as appropriate:

- the location of the facility in relation to the nearest sensitive sites (usually dwellings)

ASSESSING THE IMPACT OF ODOUR		MEASURING ODOURS	SAMPLE COLLECTION	PRINCIPLES OF PREVENTION & REDUCTION
Overview	Process (emission) based assessments	Assessment where emissions cannot be measured	Inventory of materials and odour sources	Odour impact assessment reporting

- a diagram of the installation layout and/or map showing the relative positions of the process or installation and the nearest sensitive locations
- a description of the process or activity to include throughput data, whether batch or continuous, the duration of each cycle and any other relevant information. A description of the nature of the buildings or other containment should be given if appropriate
- a description of the nature of the odour problem and the typical rate of occurrence
- complaint history - numbers, quantity, duration, frequency, any pattern or trends
- the location and nature of any other potential odour sources in the locality, if appropriate to the survey
- a description of any work previously undertaken with respect to the odour issue - perhaps previous survey work or actions taken to mitigate odours (both management of the process as well as addition of abatement equipment) and the success or failure of such measures.

iii) A statement of the objectives of the survey

iv) A description of the methodology used for sampling and analysis

A description of the main features of any standards or other methodologies used.

NB: Where olfactometry is undertaken, the guidance given in the CEN draft Olfactometry standard, ([Reference 11](#)), should be followed and all departures from the procedures described should be justified and recorded.

- a description of the equipment used for sampling and analysis
- an estimate of error associated with both sampling and analysis.

v) A description of the installation-based work actually undertaken

It is usual to consider “worst case” when carrying out an environmental impact assessment, as well as normal operation. This will entail taking samples at an appropriate time relative to the work being undertaken to account to any variation in emissions in order to avoid “averaging” the peaks. See [Section 3](#) for detail on sampling strategies.

The report should detail:

- sampling locations
- flow rates, gas temperature etc and how these were measured
- sampling times
- an explanation of why the particular sampling points and sampling times were chosen
- process activities whilst the work was being undertaken
- any arrangement made for dilution of wet or hot gases and the extent of the dilution
- weather conditions on the day of the survey and wind direction, strength.

vi) Analytical results

- raw data should be given. Lack of raw data prevents checking or validation of the scope of the assumptions made
- time elapsed between sampling and assessment
- any deviations from standard analytical/assessment methods
- details of the quality assurance provided by the testing laboratory.

vii) Interpretation of the results and conclusions drawn

See Appendix 4 of Part 1 of this note for information on recommended parameters for dispersion modelling of odorous emissions ([Reference 1](#)).

- dispersion modelling - which model was used and its suitability for assessment of odorous emissions
- a description of the data that was used as input to the model to account for topography and buildings, meteorology etc for each run. State the origin of the meteorological data obtained and which area it relates to and why it is applicable to the particular assessment. (Wind directions given by met stations would generally relate to open land)
- any features of the local topography which are likely to produce conditions which are atypical of the meteorological data used (such as more frequent inversion conditions for example) should be described

ASSESSING THE IMPACT OF ODOUR		MEASURING ODOURS	SAMPLE COLLECTION	PRINCIPLES OF PREVENTION & REDUCTION
Overview	Process (emission) based assessments	Assessment where emissions cannot be measured	Inventory of materials and odour sources	Odour impact assessment reporting

- a statement of any assumptions that have been made with respect to use of any emission factors or other predictions used in place of sampling, or to any other aspects of the release
- the results for each run of the dispersion model should be given together with an interpretation in terms of the effect on the local environment
- maps, figures and contour plots used to illustrate the extent of odour impact, including identification of specific sensitive receptors
- sensitivity analyses of model predictions to critical model input parameters should be carried out. Conclusions and assessment need to take into account uncertainties in model predictions.

viii) Recommendations and discussion

This will obviously be strongly influenced by the nature and purpose of the survey and whether the plant is existing or propose. It may cover:

- an estimation of the likely impact of current emissions on sensitive receptors
- an estimation of the amount by which emissions will need to be reduced to avoid causing annoyance
- suggested changes to the process or activity or management changes
- relevant control technology and costs if available
- measures to be employed to monitor the effectiveness of any changes or new control technology applied.

The above is not exhaustive but should be provided as a minimum (where relevant to the purpose of the survey) by a competent contractor or survey team.

The amount of detail should be proportionate to the risk of causing annoyance.

ASSESSING THE IMPACT OF ODOUR	MEASURING ODOURS		SAMPLE COLLECTION	PRINCIPLES OF PREVENTION & REDUCTION	
Practical considerations	Overview of methods	Analytic (chemical) techniques	Sensory assessment	Summary	Other means of quantifying emissions

2 Measuring Odours

2.1 Practical considerations

There are a number of factors that set odorous emissions apart from other pollutants in terms of the methods which are available for “measurement” and also the ease of measurement. These include:

Subjectivity

Most odours are mixtures of compounds and a knowledge of the chemical compounds present in a mixture does not necessarily give an indication of the human response. A subjective view - what it smells like to those who are actually exposed (ie what people may actually complain about) - can be obtained by using olfactometry and/or characterising the odour (see [Section 2.4](#)).

Variability

Seasonal variation in the level of annoyance caused by a particular source is fairly common. This may relate to differences in the process or the raw materials, degradation of putrescible materials during hot weather, or it may be simply because local residents are outside when the weather is better or have the windows open in summer. Worst case is therefore a valid consideration – and may be relevant for more than just infrequent odour events; it may occur for a considerable period of time.

Concentration in ambient air

The collection of meaningful samples of ambient air (e.g. at an affected area in the community, or at the installation boundary) for assessment by olfactometry is subject to a number of difficulties. The main problem relates to low concentration - generally too low for olfactometry - and so it is not commonly undertaken. Collection of samples for instrumental analysis is sometimes possible but fluctuation in concentration is often rapid and only direct reading instruments can give an indication of the exposure profile. A result that is averaged over a long period is rarely useful as it is the peaks which tend to cause annoyance, even if very transient. This would not normally be undertaken for routine compliance monitoring.

Use of surrogate substances for monitoring

In some cases it may be possible to set up continuous or frequent monitoring of surrogates, i.e. a single substance which is representative of the odour characteristics of the emission. Once the relationship is established, there must be a linear response to changes in total odour concentration to enable quantitative information to be obtained. Linearity is rarely maintained across the whole scale such that a near zero value for the surrogate may still leave a strong residual odour (this is often found in the waste water industry). Sometimes “calibration” values can be established to adjust for systematic non-linearity.

ASSESSING THE IMPACT OF ODOUR	MEASURING ODOURS	SAMPLE COLLECTION	PRINCIPLES OF PREVENTION & REDUCTION
Practical considerations	Overview of methods	Analytic (chemical) techniques	Sensory assessment
		Summary	Other means of quantifying emissions

2.2 Overview of methods

In general terms odour can be “measured” in terms of:

Analytical (“chemical”) techniques

- **Chemical analysis** - indirect assessment involving the collection of a sample which, when analysed, will give the concentration of the various chemical species present. This includes wet chemistry, as well as sample collection followed by instrumental analysis by means such as gas chromatography (GC).
- Direct reading **instrumental analysis** - provides information on the concentration of specific chemical species or their concentrations relative to each other. This includes portable analysers (including portable GCs and GC-MS) and the “electronic nose”, as well as colorimetric tubes.

Sensory methods (relating to human response):

- A **sensory assessment** - which gives an assessment of the physiological response to a particular mixture - strength, quality, characteristics - which provides information on the likely population response. This is obtained by exposing trained individuals to samples of the odorous air, either in the laboratory or in the field.

These categories do not have clear cut-off points and some assessment methodologies could be considered to fall into more than one.

There are a number of different methodologies in use for odour analysis. Selection of a particular method will depend upon:

- the purpose of the measurement
- the frequency of monitoring (once-off, periodic, continuous) etc
- the location at which the odour is sampled
- whether a point source or area (surface) source
- the nature and complexity of the emission - a single compound or a complex mixture.

This Note considers the following techniques and shows the context within which their use might be appropriate:

Chemical analysis (Section 2.3)

Gas chromatography and GC-MS,
Substance-specific wet chemistry methods.

Direct reading instruments (Section 2.3)

Colorimetric tubes,
The “electronic nose”,
Portable analysers.

Sensory assessment (Section 2.4)

Olfactometry,
Simplified olfactometric screening - “sniff tests”.

Where emissions cannot be measured at source it may be possible to **determine the mass emission** over a period of time from mass balance data (Section 2.6)

The collection of samples is described in Section 3.

ASSESSING THE IMPACT OF ODOUR	MEASURING ODOURS		SAMPLE COLLECTION	PRINCIPLES OF PREVENTION & REDUCTION	
Practical considerations	Overview of methods	Analytic (chemical) techniques	Sensory assessment	Summary	Other means of quantifying emissions

2.3 Analytical (chemical) techniques

Chemical and/or instrumental analysis can provide quantitative (giving a numerical concentration value) information on the compounds present. This information may be required for the following reasons:

- to assist in source identification
- for determination of compliance with substance-specific emission limits
- profiling changes in emissions during a process cycle to assist in identifying where process modifications might be made
- to set optimum operating parameters for abatement equipment (for example reagent strength, determination of breakthrough or exhaustion point of adsorbents or adsorbents).

A number of methods are described below. In any particular situation the method(s), which are suitable, may be dictated by the compounds present and the level of detail required.

Gas chromatographic techniques

Gas Chromatography (GC) is a widely used analytical technique for separating the components of an odorous air sample for identification and quantification. The majority of odorous organic species can be identified in this way.

The basic steps are:

- sampling - which may involve pre-concentration of a gaseous sample onto a solid adsorbent or absorption in a reagent
- thermal desorption or solvent extraction
- separation of the components by passing through a GC column
- detection and identification.

There are a variety of detectors available, however the most commonly used for mixtures of organic compounds is the Flame Ionisation Detector (FID). A gas chromatograph mass spectrometer (GC-MS) is more widely used for situations where the emission has an unknown composition. Identification of the resulting mass spectrographic pattern is made with reference to a computer based spectrum library, although identification of compounds with similar structures and/or masses can be difficult.

Application

- Provides reasonable quantitative analysis for a broad range of aliphatic, aromatic, alcohols and ketones.
- Provides semi-quantitative analysis for certain organic sulphides.
- Does not detect inorganic species, e.g. ammonia, hydrogen sulphide.
- Poor response to highly reactive species, e.g. amine and certain organic sulphides.

A portable **GC-MS can be used for “fingerprinting”**, i.e. to analyse air samples at the complainant’s location in order to ascertain the identity and concentration of the main odorous components. If this information does not allow positive identification of the source from a knowledge of the activities carried out, then sampling of those potential sources using the same technique can enable a match to be made. Occasionally the odour is found to be a product of more than one source, overlaid on top of each other. The extent of dilution and the need for sampling at receptors to coincide with periods of exposure (particularly if they are brief) can restrict the usefulness of this method. The cost of the instrument and the expertise required for analysis and subsequent evaluation also limit its use as a “quick check” method for everyday use. It can however be useful where there is on-going uncertainty regarding the source and who is responsible.

Disadvantages

- Direct calibration for analysing odours is difficult because the composition mixture will often be unknown.
- The concentration in ambient air of individual compounds may be below or close to the lower limit of detection.
- Longer term samples will average out any peaks, although this may be of secondary importance in source/compound identification.

ASSESSING THE IMPACT OF ODOUR		MEASURING ODOURS		SAMPLE COLLECTION		PRINCIPLES OF PREVENTION & REDUCTION	
Practical considerations	Overview of methods	Analytic (chemical) techniques		Sensory assessment	Summary		Other means of quantifying emissions

Substance-specific wet chemistry techniques

The following techniques have been used to determine odorant concentrations and are recognised methodologies for assessing compliance with emission limits. They are generally undertaken at source.

- **Ammonia** (BS 1756:1971 Part 5) - sample gas is drawn through a sulphuric acid solution. Ammonia concentration is determined by titration after Kjeldahl distillation.
- **Hydrogen sulphide** (BS3156:1968) - sample gas is drawn through an ammoniacal cadmium chloride solution. Hydrogen sulphide concentration is determined by an iodometric titration of cadmium sulphide.

Disadvantages

The detection limits achieved by these techniques is determined by the volume of gas sampled, typically limits of detection vary between 0.1 and 0.5 mg/m³. To achieve low detection limits large volumes of gas need to be sampled but, as the sampling flow rate through typical sampling equipment is limited to about 2 litres per minute, long sampling times are required and peaks in concentration will be missed. In addition the equipment is fragile and set up can be time consuming.

Colorimetric detector tubes (also called "stain tubes")

A "grab" sample of air produces a chemical reaction with chemicals contained in the tube producing a discoloration of the tube. This reaction occurs quickly, (generally within a matter of seconds), and it is possible to determine the amount of sample component reacted within the tube by the extent of discoloration (the reaction is proportional to the mass of the reacting gas).

The limits of detection for this technique are typically between 0.2 to 1 ppm, but the detection limit can vary greatly depending on the tube used. From manufacturers' literature, the relative standard deviation (coefficient of variation) of detector tubes lies between 5 and 20%.

Application:

- A wide range of tubes are available from several manufacturers covering a wide range of substances, although it is not possible to differentiate between different chemical species within a generic group.
- Sampling times are short and equipment is portable and relatively inexpensive, hence they can be used a quick indicators of poor control, to assess a short-term event or for scoping studies.
- Direct-reading colorimetric detector tubes were designed for use in testing workplace air and determining compliance with occupational exposure limits but are also are widely used to demonstrate compliance with emission limits for specific substances.

Disadvantages:

- Colorimetric tubes are not suitable for identifying unknown substances - the correct tube needs to be selected for a particular situation.
- Cross sensitivity (interference) with other chemical species is possible, for example detector tubes for ammonia may rely on a simple pH indicator reaction, thus any other basic gases (e.g. organic amines) will influence the results.
- Despite the simplicity of the method, correct use is essential or results can be highly misleading. Training will be required.
- Unused tubes must be stored correctly (some require refrigeration) and have a finite shelf life which must be observed.

The Electronic Nose

"Electronic Nose" is a generic term applied to a type of instrument which responds to the volatile chemicals in a sample by producing a pattern of electrical changes across an array of electro-chemical sensors. The sensor array fitted within a specific instrument will have been selected for a particular type of odour and then the instrument is "trained" for the specific odour-related task it is required to perform. Instruments are therefore task-specific to a large extent. The instrument responds to a change in the overall profile; if one component changes in concentration, then the relative concentration of all other components will change, although the instrument generally would not be able to identify which component caused the change.

ASSESSING THE IMPACT OF ODOUR		MEASURING ODOURS		SAMPLE COLLECTION		PRINCIPLES OF PREVENTION & REDUCTION	
Practical considerations		Overview of methods		Analytic (chemical) techniques		Sensory assessment	
				Summary		Other means of quantifying emissions	

The Electronic Nose (cont)

Application

Electronic noses are finding wide use as a quality control tool, particularly in food, beverage and perfumery as they can be taught to recognise the “good” product and then reject products whose odour profile do not match the reference standard. Similarly the quality of drinking water can be monitored as the instrument can be taught to identify various contaminants which might be present. Other applications are in medicine, recognising odours which are characteristic of particular disease processes, for stock control of perishables and for process control in industry where head space volatiles produced during manufacture can be monitored in real time, allowing feedback control loops to be set up.

Application to environmental monitoring

Applications in environmental monitoring are limited at present and the following constraints need to be considered:

- In the majority of cases the technology is unable to give *concentration or odour strength* information (although calibration may be possible in cases where process and effluent release conditions are tightly defined). It should be thought of as a “difference” monitor.
- As the instrument responds to the pattern and not the odorants themselves, it is possible that odorants which have similar profiles may be difficult to distinguish.
- A portable version was not available at the time of writing, although development work is underway on a digital hand held instrument.

Some *potential* applications are outlined below, although each specific situation will need to be assessed in terms of the capabilities and limitations of the particular instrument and advice regarding suitability for particular applications should be sought from the manufacturer. Potential applications are:

- process control - the system can be linked to an alarm if the instrument response falls outside of predefined limits
- stack monitoring for odorants - provided that the stream the composition is normally within tightly defined limits.
- effluent streams can be monitored for the presence of odorants either by purging volatiles from a liquid sample, or using existing headspace, again providing that composition is normally constant
- boundary monitoring/in-community monitoring *might* be possible using remote operation, although dilution of the source odour by air will produce a different odour profile. The instrument will only detect a difference from the baseline so it will not necessarily indicate whether it has been influenced by the source odour or by another source. Choosing the optimum site on the boundary for locating the instrument(s) may also be difficult considering meteorological variability.

Development work is on-going and it is possible that new environmental odour applications for this technology will emerge.

Portable analysers

A range of different types of portable instruments are available which could be applied to the measurement of odorants:

- portable GC-MS (see previous sub-section)
- flame ionisation detectors (FID) (see previous sub-section)
- gold leaf analysers
- paper tape monitors

Portable gold leaf analysers are frequently used on sewage treatment works, effluent plants and landfill sites to monitor hydrogen sulphide. This type of detector works by drawing odorous air into a sample port and passing it over a “gold leaf”. Reduced sulphide compounds stick to the gold leaf and a small electrical current is generated. The quantity of current generated is proportional to the amount of reduced sulphides collected. Eventually the gold leaf becomes saturated and has to be regenerated (mains electricity is used to drive off the reduced sulphides from the gold leaf).

Sampling and measurement time depend on the level of sulphides present, but typically it is less than one minute with a reported lower detection limit of 0.003 ppm. The odour threshold of hydrogen sulphide is given by as 0.005ppm by Hall and Woodfield ([Reference 4](#)).

ASSESSING THE IMPACT OF ODOUR	MEASURING ODOURS		SAMPLE COLLECTION	PRINCIPLES OF PREVENTION & REDUCTION	
Practical considerations	Overview of methods	Analytic (chemical) techniques	Sensory assessment	Summary	Other means of quantifying emissions

Portable analysers (cont)

Paper tape monitors contain a chemically impregnated tape which, when exposed to a gas sample, changes colour in direct proportion to the amount of gas present. A tape is selected which will react with the gas of interest. The monitor can be set to sample at regular intervals, exposing an unreacted section of the tape each time, and so leaves a permanent record of the concentration of each sample.

Application

A wide range of compounds can be quantified depending upon the instrument selected (manufacturer's data should be consulted) for details). A particular advantage is the ability to carry out real time monitoring and the creation by the instrument of a permanent record.

Disadvantages

- The equipment is generally expensive and, although relatively simple to operate, requires training to ensure that representative results are obtained.
- Sufficient information relating to process parameters/activities at the time of measurement must be collected to allow interpretation of the concentration data obtained.
- Some instruments are affected by the presence of moisture which limits their use for stack monitoring.

ASSESSING THE IMPACT OF ODOUR		MEASURING ODOURS		SAMPLE COLLECTION	PRINCIPLES OF PREVENTION & REDUCTION	
Practical considerations	Overview of methods	Analytic (chemical) techniques	Sensory assessment	Summary	Other means of quantifying emissions	

2.4 Sensory assessment

Sensory assessment of odours should not be thought of as less robust or less defensible than chemical analysis. It has a number of advantages.

- For a complex mixture of compounds, especially where identification is difficult and composition variable, sensory assessment provides the only reliable method of accurately quantifying the “strength” of odour.
- Sensory assessments provides a measure of the total strength of odour which may be under estimated if just a single component compound is measured.
- The sensory impact of a mixture of odorants and non-odorants can only rarely be predicted from a knowledge of its component parts.
- Sensory data provide a direct link between a particular odour and the human response to it - this is particularly important when considering annoyance issues.

The most widely used techniques are:

- dynamic dilution olfactometry - “olfactometry”
- simplified olfactometry - also referred to as “sniff tests” (a protocol is given in Appendix 8 of Part 1 to this Note ([Reference 1](#))).

Sensory assessment of odours can be undertaken at source, close to source or in the community, although increasing dilution and variability make the collection of meaningful *samples* for lab-based olfactometry progressively more difficult with increasing distance. It is possible however to take the assessment part of the procedure out into the field with perhaps a mobile laboratory or similar. A simplified form of olfactometry - “Sniff testing” - is a very useful method of assessment that can be undertaken almost anywhere.

The data obtained from a lab-based olfactometric assessment will be in the form of an odour concentration – “dilutions to threshold” or “odour units” (see Part 1 of this document, Appendix 1 – [Reference 1](#)).

The odour emission rate from a source = odour concentration x volumetric flow rate.

$$\text{(ou}_E \text{ s}^{-1}) \qquad \qquad \text{(ou}_E \text{ m}^{-3}) \qquad \qquad \text{(m}^{-3} \text{ s}^{-1})$$

Dynamic dilution olfactometry

Olfactometry involves the step-wise dilution of a sample of odorous gas with odour-free air and subsequent presentation to a panel of observers in order to determine the number of dilutions required for odour to be just perceived by 50% of the members of the panel. The most commonly used form of olfactometry is “dynamic dilution olfactometry”.

A detailed description is given in the draft CEN standard, Air Quality - determination of odour concentration by dynamic olfactometry, prEN 13725 (CEN / TC264/WG2, 1998). The most recent draft is dated 2001, with the final version expected in March 2003. ([Reference 11](#)).

The collection of samples for olfactometric testing is described in [Section 3](#) and in [Reference 11](#).

The result for each sample is typically given in terms of a number of dilutions to threshold, or in odour units - i.e. a measure of odour “concentration”. The European odour unit is abbreviated as ou_E, where one odour unit is the threshold of detection (see Appendix 1 of Part 1 of this Note – [Reference 1](#)).

During testing the character of the sample can also be described. Such descriptions can help to pinpoint where odours arise or change in character during processing. It can also be used to match descriptions given by complainants to different release points on an installation to find the source. (Refer to the table of odour descriptors in Appendix 10 of Part 1 to this note ([Reference 1](#))). With the aid of dispersion modelling the results from samples taken at source can be used to correlate complaints data.

Field of application for olfactometry

Olfactometry can be applied to:

- the measurement of the odour concentration of mixtures of odorants, and

ASSESSING THE IMPACT OF ODOUR		MEASURING ODOURS		SAMPLE COLLECTION	PRINCIPLES OF PREVENTION & REDUCTION	
Practical considerations	Overview of methods	Analytic (chemical) techniques	Sensory assessment	Summary	Other means of quantifying emissions	

- to characterise the odour.

Dynamic dilution olfactometry (cont)

Disadvantages

- In order to ensure repeatability of results a specialist laboratory should be used for analysis. The assessment should be undertaken according to the draft CEN olfactometry standard (Reference 11).
- The assessment is highly labour intensive and consequently the cost per sample is moderate to high. At the time of writing laboratory assessment typically costs about £150 per sample (average), and sample collection and transport is additional to this.
- Samples typically have a short life (less than 30 hours). Some samples have a very much shorter life.
- Total error can be considered to be of the order $\pm 40\%$.
- The draft CEN standard does not apply to samples containing odorous droplets.
- The draft CEN standard assumes that the sensitivity of odour panellists extends across a range of odorous substances. Testing of panellists is undertaken using n-butanol.



Figure 2.1: Olfactometric testing in the laboratory

Dynamic olfactometric assessment using human assessors to measure odour concentration according to EN13725

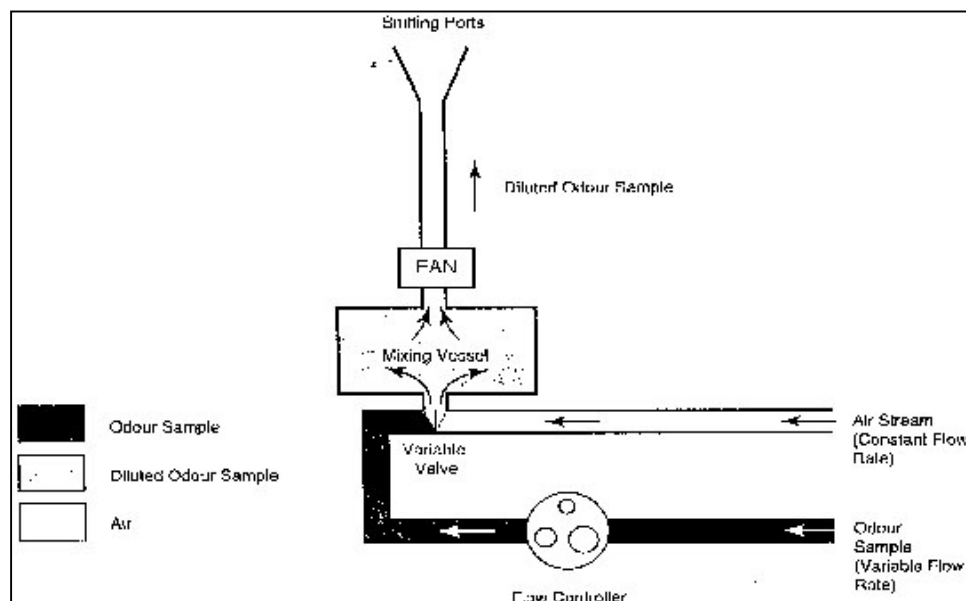

Figure 2.2: Schematic of an olfactometer

ASSESSING THE IMPACT OF ODOUR		MEASURING ODOURS		SAMPLE COLLECTION	PRINCIPLES OF PREVENTION & REDUCTION	
Practical considerations	Overview of methods	Analytic (chemical) techniques	Sensory assessment	Summary	Other means of quantifying emissions	

Simplified olfactometry (“sniff tests”)

The objective of simplified olfactometry (sniff testing) is to provide a subjective assessment of a source either at or close to the source, at or beyond the installation boundary, or at any point in the community, and to determine if possible:

- whether or not the emissions from the installation or process are detectable
- the nature of the odour and whether “offensive”
- the source of the offensive odours, if this is not immediately apparent.

This method has the advantage of speed, portability and has direct relevance to the annoyance potential. It is important to use a standardised protocol and reporting format to ensure consistency over a period of time and between different observers. A protocol is described in Appendix 8 of Part 1 to this document ([Reference 1](#)). This method should not be used where there might be any implication for health & safety of the person undertaking the test. In particular sniffing unknown substances at source, eg drums, should not be undertaken. If there is any doubt a risk assessment should be undertaken according to Agency Health and Safety procedures.

Application:

- as part of routine inspection of plant or installation operation by Regulatory officers
- can be used by process Operator as a compliance check, or to assess the state of operation
- as a part of a complaint investigation.

The procedural detail is set out in Part 1 to this Guidance Note, Appendix 8 ([Reference 1](#)).

Application of this type of technique for use in the community is discussed in [Section 1.3.1](#).

ASSESSING THE IMPACT OF ODOUR	MEASURING ODOURS		SAMPLE COLLECTION	PRINCIPLES OF PREVENTION & REDUCTION	
Practical considerations	Overview of methods	Analytic (chemical) techniques	Sensory assessment	Summary	Other means of quantifying emissions

2.5 Summary: comparison of chemical vs sensory assessment techniques

The main factors which should influence the choice of technique are:

- the composition of the odour - mixed or relatively simple
- the reason for which monitoring is being undertaken - for modelling, for assessing annoyance potential, testing of control efficiency etc., compliance
- the level of detail required
- the location of testing - at source, boundary, community
- frequency - where cost may become a factor
- the need to capture fluctuations or specific events.

Table 2.1, below, compares the characteristics of the primary techniques.

Table 2.1: Characteristics of the odour quantification methods considered

	Subjective observations	Specific chemical tests	GC-MS	Olfactometry	Electronic nose
Application	Simplified olfactometry – “sniff test”	Source sampling	Source sampling/ ambient	Source sampling	Source sampling/ ambient
Analysis	Identifying the presence of odour, offensiveness or identification of source.	Limited to specific compounds	Limited to organic compounds	Fully representative	Fully representative but appropriate sensors must be selected for application.
Sampling methodology	Testing protocol required for repeatability	Direct sampling, e.g. colorimetric tubes or instrumental. Indirect, e.g. collection of sample and lab analysis	Various techniques but will require pre-concentration for ambient air samples	Bag sampling	Direct sampling (but portability is limited)
Limit Of Detection	Typically good, but can vary depending on the environment and the compounds involved.	Depending on test – generally greater than 0.1 ppm	ca. 1.5 ug/m ³	ca. 50 dilutions	Not applicable, but detects differences, not absolute concentrations.
Uncertainty	High, improved by use of standardised protocol.	+/- 5 to 20%	+/- 10% ²	+/- 40% ¹	Not known
Ease of data interpretation	Reasonable, if protocol is followed.	Depends on the technique, e.g. colorimetric tube results easy to interpret	Often poor	Good	Good.
Relative unit cost	Low	Low to moderate. Depends on specific tests. Sample collection costs may be moderate to high.	Moderate/high. Sample collection costs may be moderate to high..	Moderate/high. Sample collection costs may be moderate to high.	Moderate/high

Key

1 - value given in “Odour control a concise guide” for duplicate samples collected and analysed.

2 - typical uncertainty value for thermal desorption and GC-MS analysis.

ASSESSING THE IMPACT OF ODOUR		MEASURING ODOURS		SAMPLE COLLECTION		PRINCIPLES OF PREVENTION & REDUCTION	
Practical considerations	Overview of methods	Analytic (chemical) techniques	Sensory assessment	Summary	Other means of quantifying emissions		

2.6 Other means of quantifying emissions

2.6.1 Use of mass balance data

Where emissions monitoring at source is not feasible, it is sometimes possible to use mass balance data/solvent use records to estimate the amount of product lost to air over a given period of time.

It will not be possible to look at emission peaks with this type of data; it will be averaged over a period of time. The peaks in concentration will be when odour annoyance is most likely to occur.

Figure 2.3 depicts the typical inputs and outputs associated with a solvent-using activity.

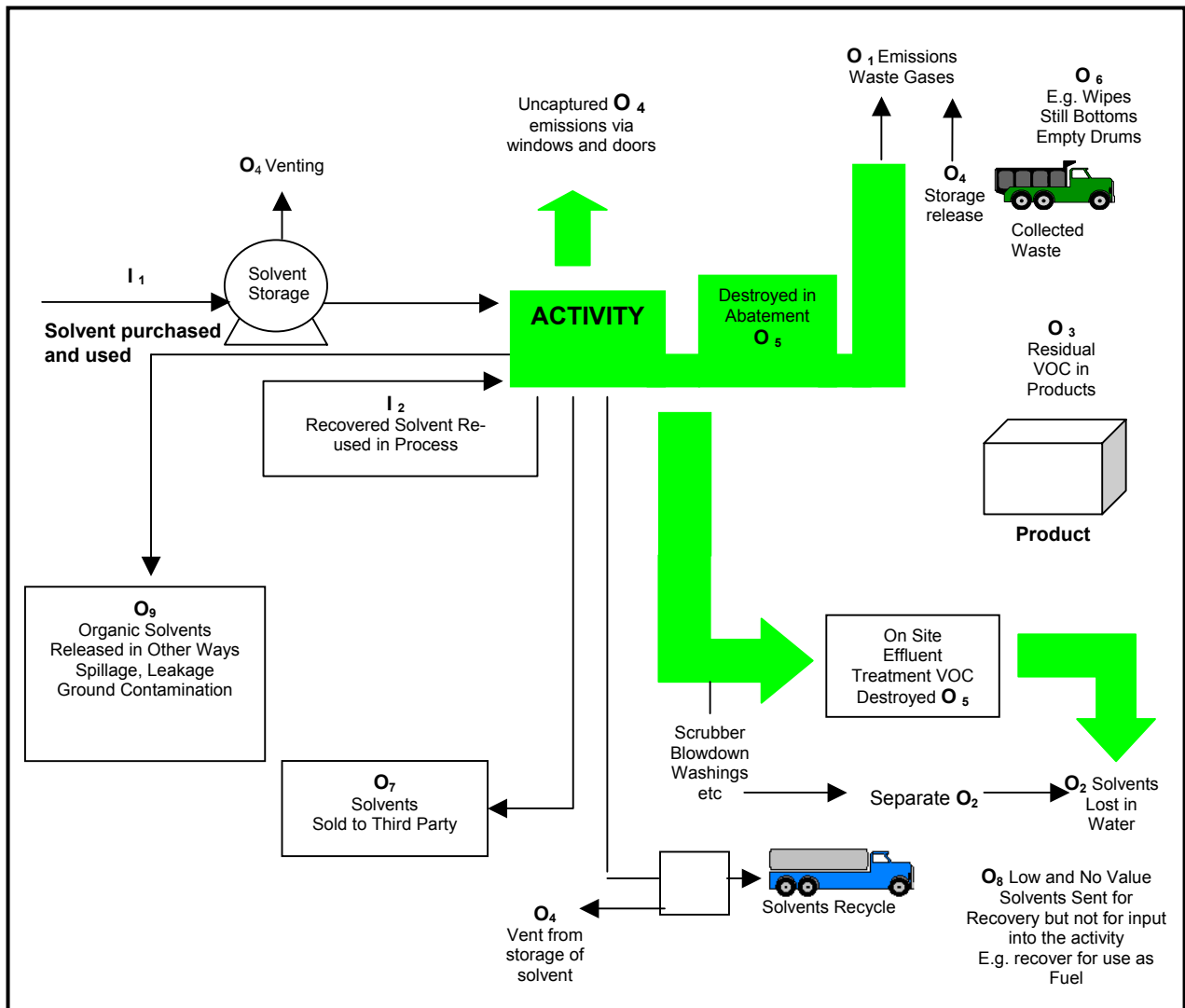

Figure 2.3: process inputs and outputs for a solvent process

In the above diagram:

Consumption = Input (I_1) less outputs sold or disposed of for recovery ($O_7 + O_8$)

Total emissions to the environment = $O_1 + O_2 + O_3 + O_4 + O_5 + O_6 + O_9$

Local emissions to air = $O_1 + O_2$ (to water) + $O_4 + O_9$

Emissions to water may flash-off locally.

3 Sample collection

3.1 Source characteristics

3.1.1 Point sources and area sources

Odorous emissions may arise from a number of different sources within a process or operation.

These may include:

- intentional point sources such as vents or chimneys
- area (or surface) sources, which can be solid (for example the spreading of wastes, material stockpiles) or liquid (storage lagoons, effluent treatment plant). These emit odours from the surface
- fugitive (unintentional and possibly unrecognised) release points such as flanges, valves, open doorways and other gaps in the fabric of buildings, uncovered skips of odorous materials etc. (This may also be referred to as “diffuse pollution”).

The nature of the source obviously has implications for control, but will also affect the means of collecting samples which represent the pattern and total emission from the installation/source.



Figure 3.1: Sampling a point source

Figure 3.2: Sampling odours from an effluent treatment plant



3.1.2 Variability

There can be considerable fluctuation within a single source, depending upon a number of factors such as the nature of the process cycle (for example, batch or continuous, variation in raw materials or by-products, throughput, process parameters) or the weather (temperature, seasonal variation in products). Open air sources may be affected by rainfall (dilution).

As odour annoyance can be related to exposures of very short duration, the need to capture the peak emissions is more important than where non-odorous environmental pollutants which have their effect over much longer time periods are concerned.

3.2 Sampling of odour emissions

3.2.1 General considerations

The purpose of the survey, the nature of the odour-producing activity and the type of source(s) will dictate to a large extent how and when samples are taken. The aim may be to consider specific aspects of the process or activity or to look at a representative case or worst case. As with any form of monitoring, the methodology employed for collection of the sample and of the supporting process parameter information is critical to the meaningful interpretation of results and the subsequent actions taken.

Proper care should be taken as regards health and safety considerations.

The following outline illustrates best odour sampling practice:

3.2.2 Sampling location

Determine the sample locations which best meet the purpose of the survey. This could entail collection at:

- specific locations on a process order to identify the point at which a specific odour arises
- a particular processing step or operation
- release points - stacks, ducts, vents, surface emitters
- in a grid pattern across an installation to establish an installation-wide “map”
- at, or close to, the installation boundary
- in the community (although the dilution of the sample can be prohibitive).

Identify the most appropriate sampling port or location with safe access. Power requirements will also require consideration.

General guidance for locating stack sampling ports is given in BS 3405:1983 ([Reference 12](#)). However, in certain circumstances emissions from point sources have to be measured from ventilation grilles (typical of general building ventilation) or roof fans (typically found on poultry houses). If this occurs, gas samples should be collected from a point as far into the duct as possible to exclude ingress of clean air which would artificially dilute the sample.

Samples collected from area (surface) sources usually give a true representation of the emission provided that any variability across the surface is taken into account. The most common surface source requiring odour measurement is a biofilter and when monitoring it is recommended that samples are taken:

- (a) close to the inlet of the bed
- (b) along the retaining walls, and
- (c) at the centre of the bed.

At each location a velocity measurement should be made to ensure that there is gas flow.

Newer biofilters are designed with a cover and release to atmosphere via a stack, where samples can be taken.

When sampling from a liquid or solid surface, an effort should be made to ensure that the sample represents the situation most likely to give rise to high odour emissions (worst case). For example when considering the emissions from a slurry lagoon, the highest odour emissions are likely to occur on parts of the surface crust which have been broken; this allows anaerobic products to be released.

Ambient air monitoring

The collection of meaningful samples of ambient air from an affected area in the community is subject to a number of difficulties.

- The size of the affected area may be large and the variation in concentration level induced by fluctuation at source and the dilution effect of possibly varying wind speed and direction makes a representative sample difficult to collect; .
- The concentration of the resulting sample may be too low to be of use for olfactometry (50 dilutions tends to be the lower limit) or other analysis.

ASSESSING THE IMPACT OF ODOUR	MEASURING ODOURS	SAMPLE COLLECTION	PRINCIPLES OF PREVENTION & REDUCTION
Source characteristics		Sampling of odour emissions	

- The number of samples which would need to be collected and assessed is potentially larger than for a survey at or close to source.

Additionally, the subsequent analysis does not distinguish from the normal background odours such as arise from traffic, grass cutting, plants etc, indeed the "normal" medley of odours amounts to anything from 5 to 40ou/m³ which could "distort" the results increasingly with increased distance from source (Reference 13).

It should be noted that there are very large uncertainties associated with the collection and analysis of ambient air samples, even if the concentration is sufficiently high for subsequent testing/assessment.

3.2.3 The number of samples required

Determine the number of samples required to adequately represent any variability in the process or operation. Emission peaks may need to be averaged within a sample or perhaps sampled separately. When considering the nature of odour and the short exposure duration (seconds) to register annoyance, it is often better to assess the magnitude of the peaks rather than to average; grab sampling may be undertaken to cover a fluctuating emission, provided sufficient sample volume can be collected. Olfactometry requires samples of approximately 50 – 60 litres, although less will be required if the concentration is high.

The number of samples required to assess the environmental impact of a particular source, or an entire installation, is dependent upon the process under investigation. There is no standardisation in terms of the number of replicate samples required. It is essential that the sampling campaign provides a representative picture of the process characteristics. Several samples taken at each point will reduce the error but this must be balanced against cost and the accuracy required. Averaging should be undertaken using the geometric mean, not the arithmetic mean, because perception is logarithmic rather than linear (see Appendix 1 of Reference 1). An odour panel will typically be able to assess a total of 20 or so samples in a day and so availability may prove to be a limiting factor. (See Section 3.2.6 – Sample life). Cost per sample for assessment by olfactometry is typically £125 - £175 at the time of writing.

3.2.4 Sampling duration

Determine the optimum sampling time to (i) cover the activities of interest (ii) collect the required volume (subsequent olfactometry may require a relatively large sample volume). The likely concentration of the odorants of interest is also relevant - pre-concentration may be required for subsequent chemical analysis. The draft CEN standard for olfactometry (Reference 11) sets out requirements for sample collection for olfactometry.

The time required for collection of a gas sample is related to the duration and variability of the emission. Depending upon the sampling equipment, the minimum sampling time to obtain a representative odour sample should be between 2 to 3 minutes. For long duration odour emissions (e.g. a batch cooking or drying operation) the collection of a number of discrete samples is preferable than the collection of one sample over the whole period. This approach avoids "averaging" out potential odour peaks, thereby ensuring that the worst case scenario is sampled.

Section 3.2.7 shows the effect of replicate samples on confidence intervals.

3.2.5 Sample collection procedures and equipment

Standard methodologies for odour sampling are described in:

- a) the CEN draft Olfactometry standard entitled, "Air Quality - Determination of Odour Concentration by Dynamic Olfactometry" (CEN/TC264/WG2-Odours), (CEN standard prEN13725)
- b) the CEN draft regarding Volatile Organic Compounds (VOCs) entitled, "Stationary Source Emissions - Determination of Individual Gaseous Organic Compounds" (CEN/TC264/WG4 - Total Organic Compounds).

The collection methodology employed depends on the nature of the gas stream, e.g. temperature, moisture amongst other properties, and the intended method of analysis. Other standards will apply to the collection of samples intended for different forms of instrumental analysis.

Any derogation from the relevant standard should be noted and justified.

If **olfactometry** is to be undertaken, particulate will need to be filtered out during sampling. The fraction may be important as odorants may be adsorbed onto particulate matter, or particulates may break down in the atmosphere and release odorants. Separate examination of the filter may be appropriate. Requirements for filtering are discussed in the CEN olfactometry standard.

Where gases are hot and wet, pre-dilution may be required to avoid condensation in the sample container when stored at ambient temperature. Pre-dilution devices need to be regularly calibrated to avoid excess error.

The most commonly used sampling techniques are:

- collection of whole gas sample
- collection of gas by adsorption (although this is of lesser importance with respect to odour).

The sampling techniques are described in more detail below.

The typical equipment used for collecting odour samples is shown in [Figure 3.3](#) below.

Sample collection is based on the “lung” principle. The sample bag is placed inside a rigid container. The air is withdrawn from the container using a vacuum pump. The sampling tube (inert PTFE) is placed into the sample port and the low pressure in the container causes the bag to fill with a volume



from the sample gas stream which is equal to the amount which has been withdrawn from the container. Sample bags are made from Tedlar, (a proprietary material) or other similarly inert material. ([Figure 3.6](#)). Samples should not be collected by direct pumping because of the risk of adsorption or contamination.

The volume of gas sampled must be sufficient to allow any subsequent analysis to be undertaken. A volume of between 40 and 50 litres is generally sufficient. The sample should be stored at temperatures of less than 25°C and the draft CEN Olfactometry standard allows no more than 30 hours to elapse between sampling and assessment. It has been found that a sample held for 30 hours can lose approximately 25% of its odour strength (losses arise primarily from surface adsorption, leakage and moisture). It is therefore recommended that the analysis is undertaken as soon as practicable after collection, preferably in under 8 hours. A schematic view of a typical sampling train is given in [Figure 3.4](#)

Figure 3.3: Odour sampling apparatus

Figure 3.4: Schematic of sampling equipment

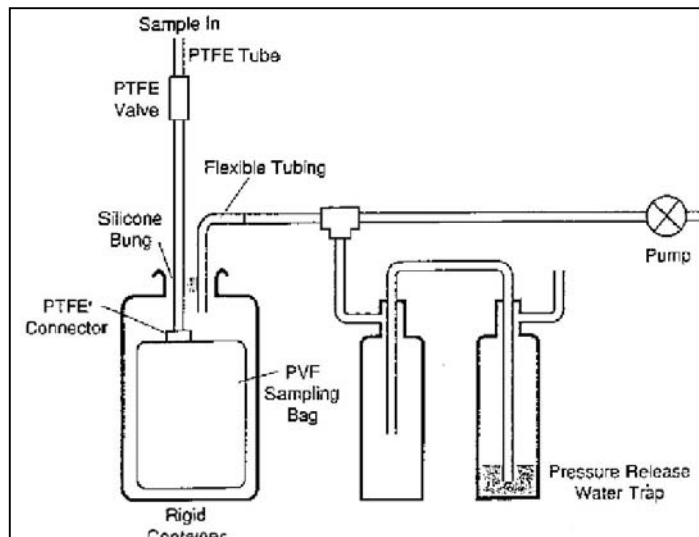

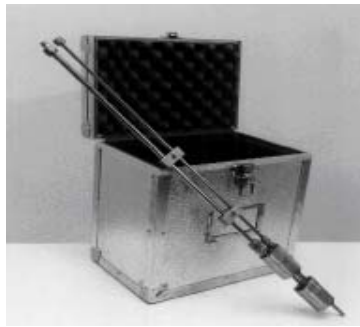

Figure 3.5: Dilution apparatus.



Figure 3.6: Empty sampling bags

If condensing gases are present (hot, moist gases), pre-dilution is required. For static pre-dilution, the sample bag volume should initially be determined and then partially refilled with a known volume of odourless gas (ideally nitrogen) prior to sampling. The ratio of gas sample volume and total bag volume is known as the dilution factor. For dynamic pre-dilution where the sample is diluted by a pre-set amount as it is collected, a calibrated dilution probe must be used and the diluted gas collected in the sample bag.

Collection of a gas sample by adsorption

This technique is widely used, but the appropriateness of its use in odour annoyance situations should be considered carefully as the peaks will be lost in the process of averaging. It may be better to use a portable instrument and sample in real time if this is possible.

If gas chromatography is to be used to determine the composition of a sample of odorous gas, it is important to collect sufficient material, i.e. in terms of concentration, to give good resolution upon separation and subsequent detection. This can be a problem with odour samples because the threshold of detection is very low for many odorants but a sample (particularly if collected at a distance from the source) may be too dilute for analytical purposes.

In some circumstances gas samples can be collected directly onto a suitable adsorbent, by drawing a known volume of air through an adsorbent material.

Alternatively, the bag sampling method can be used to extract and collect a gas sample and a portion of gas can subsequently be adsorbed onto a suitable adsorbent material such as Tenax® or activated carbon. Collection of a bagged sample prior to adsorption allows the effects of high temperature and moisture to be mitigated by dilution with odourless gas, as described above. It is strongly recommended however that drying agents such as sodium sulphate should not be used to precondition samples prior to the adsorption as the odorous compounds may be adsorbed onto the drying material.

It is often necessary to pre-concentrate samples of ambient air. The sample can be collected by passive diffusion onto an adsorbent (as above) over long exposure periods (>7 days if required) or by actively pumping over a period of approximately 8 hours or less. ***Time averaged values are obtained but the peak concentrations which may give rise to annoyance are not able to be quantified as they will be averaged out. This restriction may nullify the whole purpose of the assessment by missing the points of particular interest.*** Other critical parameters in ambient air sampling are the choice of location and timing; obviously the odour under investigation must occur during the sampling period for the exercise to be of use.

Sampling of non-point (area) sources – where there is a gas flow

Collecting samples from a surface source where there is gas flow, for example a biofilter, can be achieved by covering a portion of the surface with a hood. Prior to sampling, the hood should be left in place for 10 to 20 minutes (to ensure that any trapped clean air has been displaced) and then a gas sample can be collected, [Figures 3.7](#) and [3.8](#).

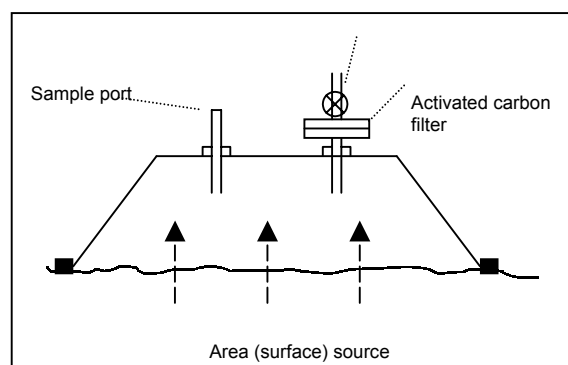

Figure 3.7: Schematic of equipment for collecting a sample where there is a gas flow.



Figure 3.8: Sampling from a biofilter

Sampling of non-point (area) sources – where there is NO gas flow

Collecting samples from an area source where there is no flow, such as solid waste, lagoon or effluent storage tank, can be undertaken by covering a portion of the surface with a suitable ventilated canopy, (Figure 3.9). The canopy is ventilated with odour free air at a known volumetric flow rate. A gas sample can then be collected at the outlet of the canopy. In calculating odour emission rate, the odour concentration of the ventilation gas should be taken into account.

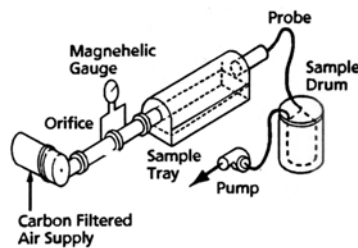
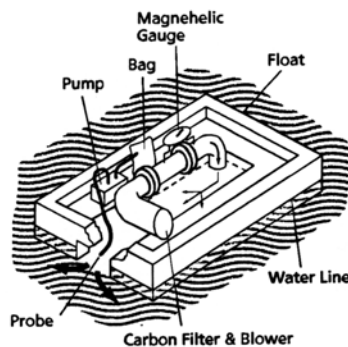

Figure 3.9: Equipment used for sampling from liquid and solid sources where there is no flow (top: solid surfaces, bottom: liquid surfaces)

When using the ventilated sampling canopy method, the choice of the correct parameters of operation is of vital importance. The sampling hood must use a flow velocity under the hood of 0.2-0.3 m s⁻¹ and have a headspace height of no more than 200 mm. The path length must be sufficient to allow the concentration under the hood to reach values that can be readily measured using olfactometry. Generally speaking olfactometry becomes more difficult at concentrations below 50 ou_E·m⁻³ because of background odours in sample bags etc.



As an example, a Lindvall type sampling hood of suitable dimensions is pictured in Figure 3.10. The section of the headspace is 160 × 160 mm with a total path length of 6 × 960 = 5760mm. The “hood constant” L can be calculated as:

$$L = \frac{\text{flow path section [m}^2\text{]}}{\text{covered area [m}^2\text{]}}$$

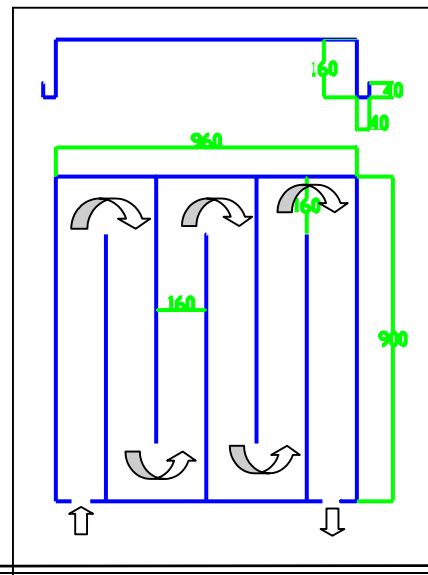

Once the hood factor L is known, the specific emission rate can be calculated from the concentration measured at the exit of the hood and the flow velocity V:

$$E_{sp} = C_{hood} \times L \times V$$

In the example the hood factor L is 0.027778, and the low velocity V = 0.25 m s⁻¹, which implies that at a specific emission rate (E_{sp}) of 1 ou_E m² s⁻¹, an odour concentration of 144 ou_E m³ is measured at the exit of the hood.

Figure 3.10: Air flow through a Lindvall sampling hood

This implies that emission rates as low as approximately $0.5 \text{ ou}_E \text{ m}^2 \text{ s}^{-1}$ can be measured without coming too close to the lower detection limit of the method of the odour concentration measurement (approximately $50 \text{ ou}_E \text{ m}^3$).



Figure 3.11: Demonstration of a sampling train using a sampling hood

Other methods for assessment of emissions from liquid and solid sources (such as odour potential - described below) are available and should be tailored to the specific requirements of the source.

Odour potential

An alternative method for “measuring” odour emission from liquid sources is to derive an odour potential as shown in Figure 3.12. The procedure involves placing a known volume of odorous liquid into a sealed container with a head space approximately equivalent to the sample volume required. The liquid is allowed to stand for about 10 minutes and odourless air is passed through the liquid at a rate of 1 to 2 litres per minute. The exiting gas is collected in a suitable sample bag. Static pre-dilution may be needed to avoid high moisture content which can affect sample integrity. Samples can then be subjected to olfactometry. Odour impact assessment can then indicate the potential for causing annoyance.

Figure 3.12: Obtaining a representative odour sample from a liquid

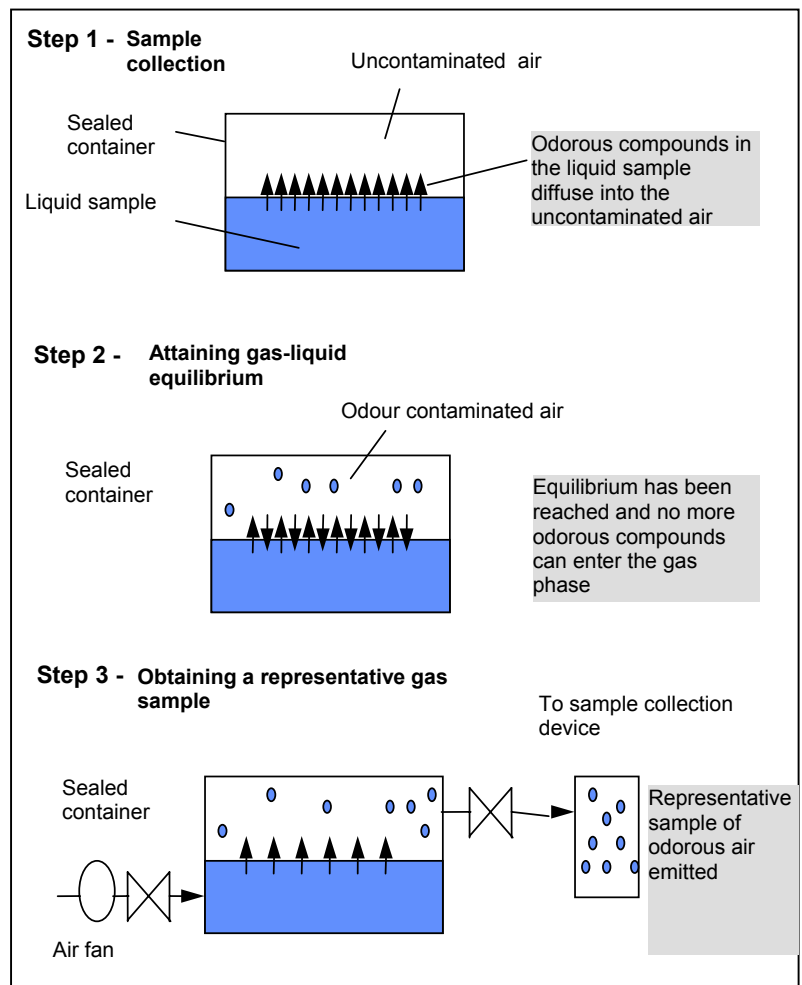

To convert odour potential to odour concentration or odour emission an understanding of the mass transfer mechanics of the gaseous emission process is required. This approach is widely used in the waste water treatment industry and has the advantage that floating hoods are not required (possible safety hazard).

It could be applied to on-site effluent treatment plant but the mass transfer characteristics of the compounds of interest must be understood. If a single marker compound is identified, it must be representative of the odour as a whole.

[Reference 7](#) Agency R&D report P4-079/2 “BAT for odorous releases” contains a case study which describes the use of odour potential for collecting samples from an effluent treatment plant.

3.2.6 Sample life

Samples for olfactometry have a short life span and need to be analysed within a maximum of 30 hours of sampling. Panellists are sometime recruited close to the sampling site to avoid over-extending the sample life - but this has a number of pitfalls, as well as some advantages. This will not comply with the CEN standard however.

3.2.7 Limits of detection and uncertainty

The lower limit of detection for olfactometry is, by definition, $1 \text{ ou}_E \cdot \text{m}^{-3}$. The odour concentration of the sample is then expressed as a multiple of one European Odour Unit per cubic metre ($\text{ou}_E \cdot \text{m}^{-3}$) at standard conditions for olfactometry (Room temperature (293 K), normal atmospheric pressure (101,3 kPa) on a wet basis).

The lower limit of detection for a sample is 50 ou_E , ie it must be at least 50 ou_E as collected to allow it to be diluted and presented to the panel at a number of different dilutions (as per the CEN standard).

The performance of odour concentration measurements has been defined in the performance criteria of the CEN standard. These imply that for one single measurement result, the 95% confidence interval will be:

The geometric repeatability of the sensory calibration with n-butanol is $r' \leq 3$, complying with the EN13725. The confidence limits for a value x for two measurements ($k=2$) is:

$$x \cdot 2.09^{-1} \leq x \leq x \cdot 2.09$$

In other words, if the real concentration is 1000, the result of analysis will in 95% of cases lie in the interval between 571 and 1752 $\text{ou}_E \cdot \text{m}^{-3}$. Analysing more than one replicate of a sample can reduce the uncertainty. [Figure 3.13](#) shows the 95% confidence interval for replicated measurements, for the repeatability that is required in the EN13725 standard. Refer to the CEN olfactometry standard for more detailed information ([Reference 11](#)).

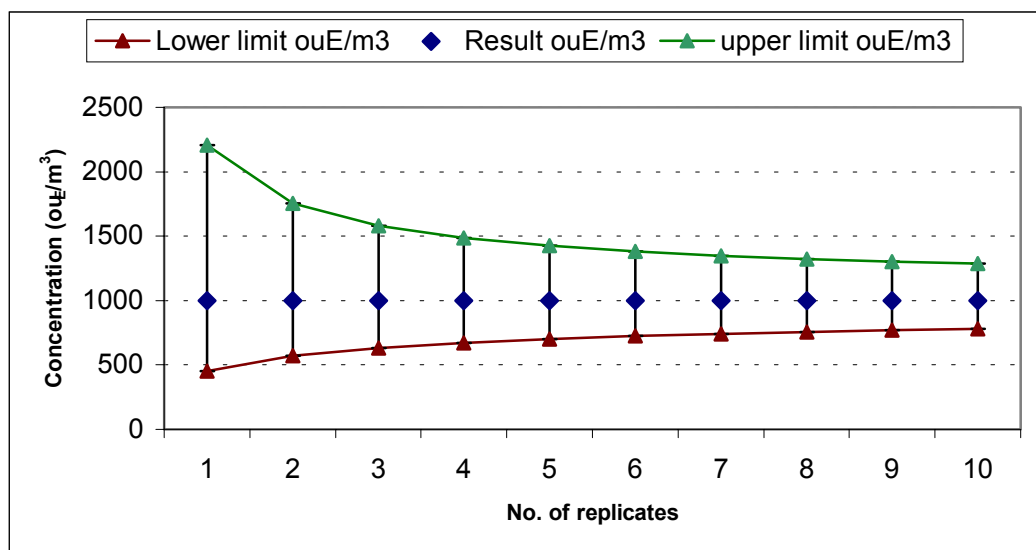

Figure 3.13: Confidence intervals for replicated measurements using dynamic olfactometry according to EN13725.

The true value is assumed to be $1000 \text{ ou}_E \cdot \text{m}^{-3}$

4 Principles of Prevention & Reduction

4.1 Preventing and reducing emissions

Measures for preventing or reducing odour need to be considered on an operation by operation basis.

Emphasis should be on:

- **good process design or redesign. Utilising “clean technology”, i.e. design the problem out rather than relying on “end-of-pipe” technology to clean up afterwards**
- **good operating and management practice backed up by an environmental management system**

Dealing with an odour problem at source by means of process design or modification, or managing the activity differently, almost invariably brings long-term cost savings when compared to the addition of end-of-pipe abatement options, which have the following disadvantages:

- they do not deal with the root cause/source
- capital & running costs are often high
- emission routes for pollutants may simply be changed to another media
- there is often a residual waste to dispose of
- energy consumption can be high.

Conversely, process-based control brings about:

- more effective and efficient process management
- better operator awareness
- less waste produced
- long term cost savings are possible.

In practice, the optimum solution in the short term may be a combination of both, although the long-term aim should be towards the adoption of cleaner technologies.

The above should be set within a framework of good operational and management practice. Some forms of activity, particularly those which involve operations which cannot be enclosed rely heavily upon good management practice.

Examples of good odour reduction practice

Examples of good practices to avoid or reduce odour-related annoyance include, as appropriate to the situation:

- Substitution of raw materials or other process inputs to prevent or reduce odour generation.
- Adjustment of process parameters such as temperature, duration, pressure and venting to reduce formation and/or release of odorous by-products.
- Contain odorous air within process machinery to avoid contaminating the much larger volumes of “ventilation air” within buildings. The overall cost of treating an odorous gas stream is determined to a large extent by the volume of air involved. Good containment of intensely odorous process gas and effective treatment prior to discharge or to mixing with general ventilation air can remove the need for treatment of a much larger volume.
- Maintain the integrity of process buildings by keeping windows and doors shut. Remotely operated roller doors can minimise the amount of time that doors are open, or alternatively flexible industrial curtains can be used across doorways (if visual obstruction is not a problem). Siting doors on opposite ends of a building can create a through draft which carries odour out and should be avoided where possible. For very odorous processes the use of air-lock entry and exit doors and maintenance of negative pressure within process plant or within process buildings will prevent egress of contaminated air. Obviously and implications for the health and safety of people working inside should be considered.
- In the case of open air operations, observe good practice relating to covering of odorous materials, housekeeping, mixing of materials, venting, design etc. See [Reference 9](#) for advice relating to odour control for those activities covered by the Waste Management Licensing regime.

- Transfer odorous materials in automatic flow demand systems rather than in batch containers where possible. Vapour balance lines should be installed for tanker loading or offloading of odorous materials and also for tank transfers. Tankers should use dry break couplings to minimise the potential for spillages. Where there are only occasional transfers of substances which have no environmental impact in air other than their odorous nature, it *may* be sufficient to move the loading point to the furthest point from the sensitive receptor.
- Cover tanks/lagoons of odorous waste where possible. Fill from the bottom with submerged pumps to avoid disturbing the surface.
- Maintain seals, glands, pumps and other potential fugitive release points within a planned programme of preventative maintenance and implement a leak test regime. The design specification for pumps, valves, pipe flanges, relief valves and bursting discs etc should be reviewed.
- Avoid mixing incompatible materials which may produce malodorous breakdown products.
- Ensure that raw materials, products and wastes are stored appropriately. The condition of incoming material may need to be monitored, putrescible materials should be rotated on a first-in, first-out basis and refrigerated where appropriate (there may be seasonal variation in the “shelf life” of putrescible materials).
- Avoid conditions which encourage anaerobic breakdown.
- Good housekeeping - avoid build-up of malodorous materials and wastes except in designated (and appropriately managed) areas.
- There may be opportunities to adjust operating times to avoid weekends or evenings, or to run a particular process only when the wind is favourable.
- Ensure that staff receive suitable and sufficient training relating to odour control and are aware of relevant licence conditions and emission limits relating to their work.

If actions taken to minimise odour cannot in themselves meet the appropriate emission limit or other Permit condition, a reduction in the mass of odour which needs to be subsequently treated make abatement significantly more cost effective. ***The overall cost of treating an odorous gas stream is largely dependent upon the volume of air involved.*** Reduction of this volume as far as is safe and practicable can reduce costs considerably.

4.1.1 Odour dilution as a means of control

For the purposes of this guidance, dilution is taken to be the act of increasing the amount of clean air mixed with odorous air prior to discharge in order to reduce the impact.

A common misunderstanding is that diluting odorous air prior to stack discharge minimises the potential for odour annoyance at sensitive receptors. - **this is incorrect!** Increasing the air volume will change the characteristics of the emission, such as increasing the efflux velocity, and therefore increase the effective stack height. This will have some effect on the dispersion characteristics of the emission, but dilution itself does not alter the mass odour emission.

Within the field of odour control, it is usual practice to use “dilution factors” when quantifying odorous gas concentrations. However, this is not the same as diluting to attempt to minimise the impact, and can be a very misleading concept when considering dispersion. For example:

if X ($\mu\text{g m}^{-3}$) is the concentration of the odorous substance at the chimney
 X_0 ($\mu\text{g m}^{-3}$) is the 50% odour detection threshold,

then the dilution factor D is given by X/X_0 ;

D is the number of times the gas must be diluted by atmospheric dispersion before reaching ground level or some other receptor area in order to avoid the possibility of detection by at least 50% of the population.

If the gas flowrate at the chimney exit corresponding to X is F ($\text{m}^3 \text{s}^{-1}$), then for the same total emission rate of the odorous substance doubling F will halve X . However, in the majority of cases the perceived odour concentration does not depend on the initial concentration at the chimney exit but on the emission rate, Q .

In the case of odours, $D \times F$ gives the odour emission rate E ($\text{m}^3 \text{s}^{-1}$) which is equivalent to Q/X_0 ; and E is the parameter which defines chimney height. **Any decrease in D achieved by increasing F does not affect E .** Hence, the use of dilution is ineffective for odour abatement.

The perceived odour level at a given receptor point is more a function of odour mass discharged rather than the actual odour concentration. Therefore the mass released needs to be reduced to have any effect.

4.1.2 Separation distances/buffer zones

A simple and effective way for the operators of landfill and livestock operations to minimise odour complaints has been to locate their process(es) as far as way as possible from inhabited areas. This however can be a short term panacea as housing development spreads. The use of buffer zones is only relevant as a means of control where odour is emitted at low level, i.e. it does not apply to stack discharges which can travel for some distance before grounding.

The Town and County Planning General Development Order of 1988 identified those developments that could be carried out on agricultural land without planning permission. However, planning permission is required for certain new facilities (e.g. livestock buildings, slurry storage and sewage sludge facilities) and for extensions or alterations to similar structures within a distance of **400 metres** from the boundary of any protected buildings (e.g. houses and schools). Hence, there is an incentive for operators to site any new process(es) at least 400 metres away from the nearest protected building.

There are however several difficulties with this strategy, particularly as it does not take farm size or production levels into account. Farmers may find themselves required to undertake further measures where odour-related annoyance is a problem beyond the 400m boundary. Housekeeping measures and building design have been shown to have significant effects on odour reduction.

See [Reference 5](#): "Odour management at intensive livestock installations", Environment Agency.

[Reference 2](#) describes the use of setback distances in the Netherlands.

4.1.3 Landscaping (tree planting and earth banking)

This approach is all too frequently quoted as a solution for dealing with an odour problem. It has been said that in some circumstances there *could* be a demonstrable positive, although minimal, effect. However there is no conclusive evidence to show any real and sustained odour removal or dispersion effect resulting from landscaping. It is more likely the case that breaking the line of sight has a psychological effect of lessening perception.

4.1.4 Dispersion

Where odour cannot be prevented, containment and often some form of treatment is followed by release to atmosphere and reliance is placed upon sufficient dispersion taking place before sensitive receptors are reached.

Appendices 5 and 6 of Part 1 of this note ([Reference 1](#)) outline the benchmarks that are available to describe an "acceptable" level of odour exposure at sensitive receptors.

Dispersion modelling of releases is described in Appendix 4 of Part 1 of this note ([Reference 1](#)).

A knowledge of what constitutes an acceptable level of exposure can be used in calculating a suitable chimney height for dispersion of residual odours.

However the following should be borne in mind.

- The magnitude and frequency of the peaks in concentration are often the factors that determine whether an exposure is acceptable or not. Point sources at a height can produce considerably larger peak to mean ratios than ground level sources.
- Increasing the effective chimney height may reduce or eliminate complaints close to source but may not reduce complaints further afield. Complaints from further afield may actually increase with increased effective chimney height if dispersion is poor.

Reducing the mass emission is often more effective than increasing the chimney height. (see [Section 4.1.1](#)).

HMIP Technical Guidance Note D1 – Dispersion (Reference 17):

HMIPs Technical Guidance Note (Dispersion) D1 is a nomograph model based on an extended series of runs of an R91 model. It may be used to calculate the stack height required to disperse odour so that odour concentration at the location of greatest impact averaged over a period of 3 minutes to an hour is less than specified limits. Technical Guidance Note D1 allows the effects of buildings to be taken into account.

The model as published was not originally intended for application to odour dispersion. However, Woodfield and Hall have prepared further guidance on the application of the method to odour dispersion in "Odour measurement and control - An update", Department of the Environment, 1994 (Reference 4). The use of a peak to mean ratio of ten is recommended. A similar factor may be suggested for application of other models that calculate hourly average concentrations. The factor may be reduced somewhat where the dispersion is affected significantly by buildings or for relatively low level stacks.

There have, however, been reports of stack heights calculated using D1 proving to be too high or too low for specific applications and it is suggested that specialist advice is sought and detailed modelling carried out prior to committing to expenditure. It should be used as an indication only.

4.1.5 Other techniques

- Use of floating plastic balls on open tanks and or lagoons to minimise the area of volatilisation. However, when balls are floating free on odorous liquids the balls may become coated as they roll about and themselves become sources. To avoid this, the balls need to be joined together in a linked net fashion.
- Use of tank covers.
- Bottom filling of tanks/use of submerged pumps to avoid disturbing the surface.
- Avoid build-up of sludges in biological treatment tanks which can breakdown anaerobically.
- Aeration of slurry tanks (although the odorous gas given off may need to be treated).
- Use of sub-soil slurry injectors instead of the conventional splash plate when slurry spreading (refer to Reference 5 for more detailed information).
- Repositioning of tank vents to less sensitive locations/ground level.

4.1.6 Containment

Containment may be a prelude to treatment or may be able to stand alone as a means of preventing offensive odour from escaping the process or installation boundary. Some processes are obviously not amenable to enclosure, for example landfill and effluent treatment, although for the latter localised enclosure of some parts of the process may be possible. See Figure 4.1.

Containment can be achieved by eliminating unintentional holes in buildings and keeping doors and windows closed, avoiding the storage of odorous materials outside the building and the transport of materials between buildings in open containers etc. Containment of highly odorous process gases, i.e. keeping it separate from less odorous streams, may reduce the capital and operating (energy costs etc.) of the required abatement system(s).

As a general rule all odour control systems should exert a negative pressure locally or within process buildings to prevent odorous air leaking out. Actions taken should not compromise the health or safety of those working inside.

Testing of buildings, tanks and storage areas using smoke generators can provide a quick and easy means of identifying holes and leaks from which odour may escape. Leak testing in this way often provides a very positive initial step in a programme to identifying odour sources, and can all help in creating a more efficient negative pressure system.

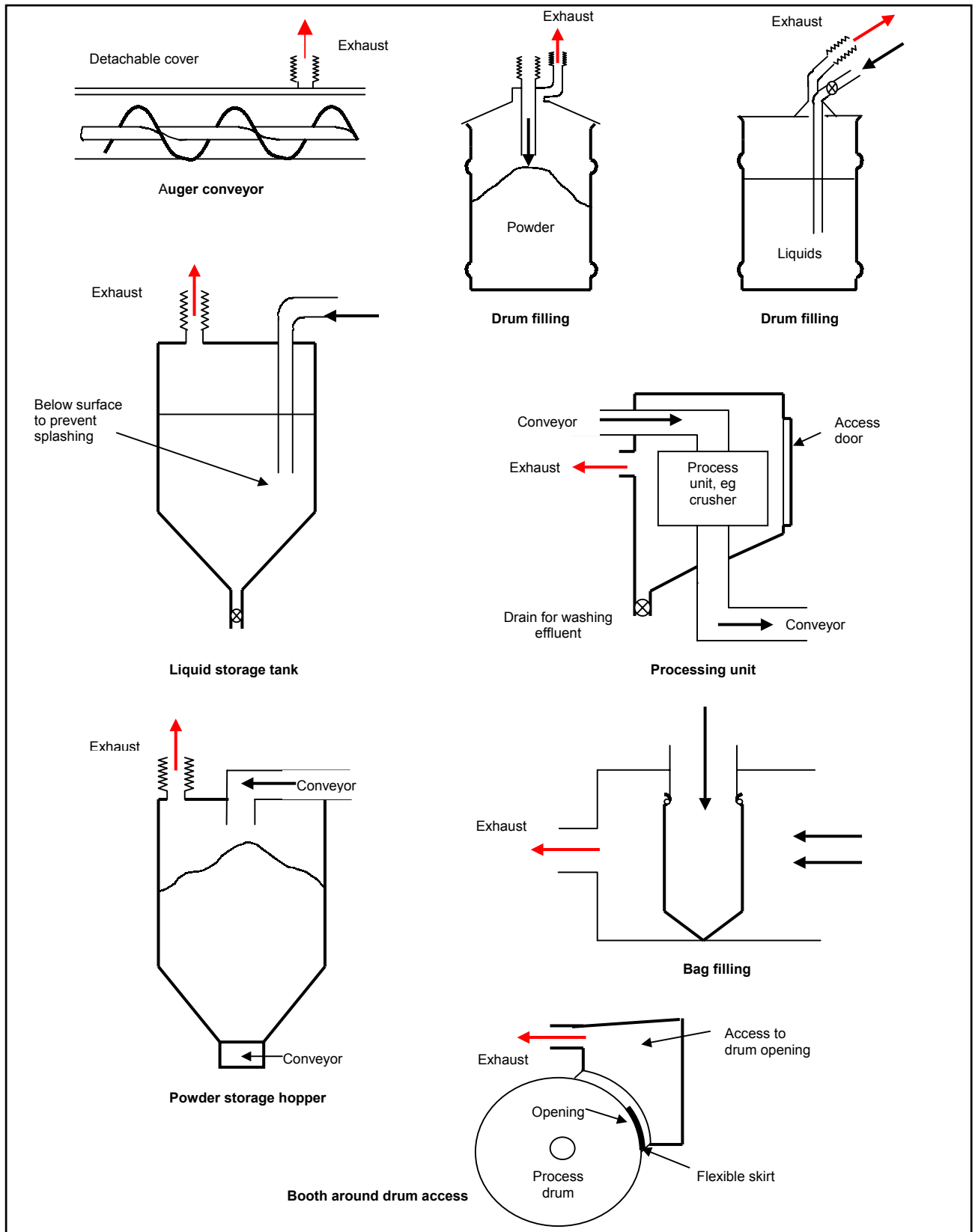

Figure 4.1: Examples of enclosures and exhaust systems for odour (continued overleaf)

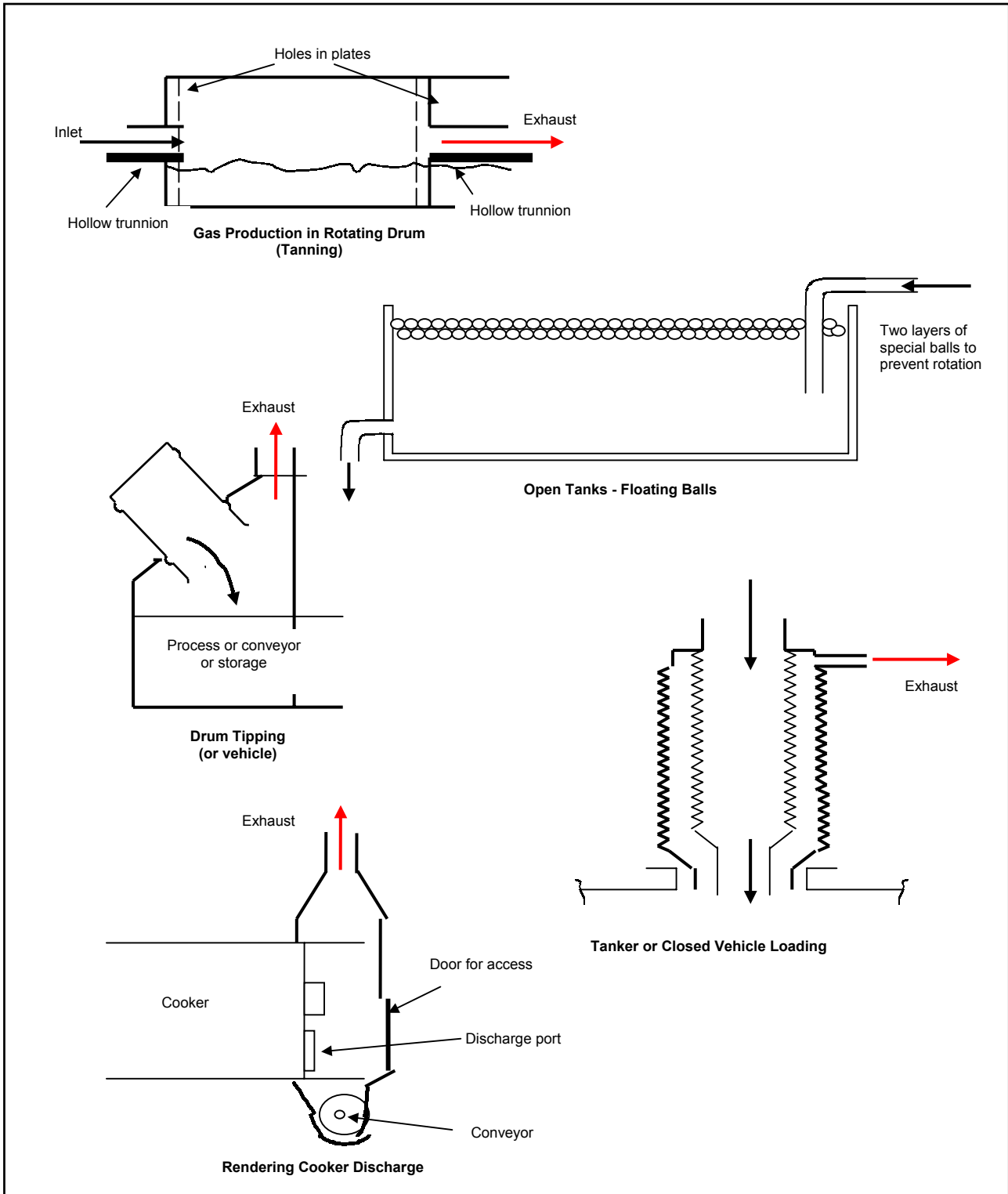

Figure 4.1: Examples of enclosures and exhaust systems for odour (continued)

4.2 Abatement techniques (“end-of-pipe” techniques)

4.2.1 General

An odour control strategy should aim to prevent odour from being generated, but where this is not practicable, the rate of odour generation should be minimised and end-of-pipe abatement considered, as appropriate to the nature of the gas stream and the source type. Specialist advice should be sought and/or trials undertaken to determine the suitability and efficiency of a particular option prior to committing capital expenditure.

General considerations

- A reduction in the volume of gas to be treated can reduce abatement costs considerably.
- For each potential treatment technique consider the nature and strength of the residual odour after treatment - will subsequent dispersion in the atmosphere cause annoyance and will it meet required limit or Permit condition?
- Does the chosen technology have the ability to deal with fluctuations in input stream (where appropriate)?
- Equipment must be appropriately sized - it should be able to deal with existing maximum throughput plus any envisaged expansion, but over-sized plant is a waste of money.
- As part of the selection process, the monetary cost of treatment should be weighed against the benefit to the environment and the waste streams generated, and also the cost to the environment of taking a less effective option - this is particularly relevant for IPPC.
- What is achievable within the cost benefit balance of BAT?

4.2.2 Criteria to consider in the choice of technique

Usually there will be more than one method of abating a particular odour stream and a number of factors will need to be considered as part of the selection process. To assist in the choice there are several rules of thumb that can be used for guidance:

(i) Type of gas stream

The choice of odour abatement equipment is dependent on the type of odorous stream to be treated. There are two typical types of odorous gas stream:

- process gas stream (typically high odour concentration, low flow)
- ventilation gas (typically low odour concentration, high flow).

It is often more cost effective to treat the process and ventilation streams separately.

(ii) Properties of the gas to be treated

• Particulates and Aerosols

Some processes are very dusty with a significant proportion of odour being associated with the dust, for example some pharmaceutical processes, poultry farms and animal feed compounders. It may be possible to significantly reduce odour by removing the dust or droplets from the exhaust by filtration or mist eliminators. Preliminary particulate control will be required upstream of some forms of abatement equipment, for example packed bed scrubbers will need protection.

It may be possible for the collected particulate matter to be recycled, particularly if it has some value.

- **Concentration and volume of pollutants**

The perceived strength of an odour is not necessarily associated with high chemical concentrations. However, generally:

- where high odour/pollutant concentration is associated with small air volumes, incineration may be the only effective odour control option, although an assessment of volume and loading may show adsorption on carbon units to be worth considering
- multi-stage scrubbing is often more cost effective for larger volumes of highly polluted air
- medium and low odour/pollutant concentrations are liable to be associated with larger air flows, such as building ventilation systems. They are likely to require abatement by techniques with lower operating costs such as biofiltration

- **Temperature**

The temperature of the gases to be treated will affect the abatement options which are available or may dictate the need to fit additional pre-conditioning units, such as a gas cooler or condenser. For example, biofilters and carbon adsorbers are unlikely to be effective if the gas temperature is in excess of 35°C and 40°C respectively. Conversely, high exhaust temperatures may reduce running costs if incineration was an option.

An additional factor affecting odour abatement is the effect of the temperature on the material of construction. Plastic is frequently used because of its anti-corrosion properties and relatively low cost, however it can be susceptible to thermal damage.

- **Moisture content**

The moisture content of the exhaust gas will also affect the choice of abatement technique. High moisture content is likely to reduce the cost effectiveness of adsorbers due to the preferential take up of water vapour. High moisture content is slightly beneficial for biofilters because it reduces the amount of irrigation the bed requires and it has no detrimental effect on scrubber performance but it will adversely affect the cost of incineration as an option.

- **Chemical composition**

The chemical composition of an odorous gas stream can affect the suitability of various abatement options in several ways. For example:

- organic compounds may not be suitable for abatement by a water based scrubber but may provide a significant fuel fraction for an incinerator
- incineration of a gas stream with a high sulphur loading would lead to the formation and release of acidic oxides, unless the incinerator had been designed to withstand and remove these prior to release
- acidic and basic gases are readily removed in chemical scrubbing by use of a neutralising chemical - for acid gases this would be an alkali
- easily soluble organic compounds are most suited to bioscrubbing or biofiltration, whereas aromatic compounds and those containing halogens are more difficult to oxidise by this method.

(iii) **Physical constraints of the technology**

- **Disposal of waste products**

When deciding upon the choice of odour abatement equipment, safe (and legal) disposal routes for secondary wastes, such as scrubber liquor and sludges and saturated carbon, will need to be considered as part of the overall environmental impact, as well as the additional cost.

- **Other considerations**

- Physical size - available space may be at a premium.
- Energy usage and noise output.
- Safety considerations.
- Reliability and maintenance requirements (including down time, start-up, shut-down requirements).
- Seasonal fluctuation, for example external biofilters will be subject to lower ambient temperatures during winter months but may be at risk of drying out during dry months - both of which can adversely affect performance.
- Complexity and need for training and skilled staff.
- Consistency of concentration and composition.

(iv) Location and local factors

The proximity of residential dwellings or other occupied buildings such as adjacent businesses and the population density will have a bearing on the degree of removal required (within the constraints of BAT) to avoid annoyance.. Local topography, prevalent weather conditions and height of discharge will affect transport through the atmosphere of the residual odour after treatment.

(v) Required efficiency and cost (cost/benefit)

In selecting abatement equipment the objective would generally be to reduce the odour emission to such an extent that the residual odours do not lead to annoyance at sensitive receptors, as far as BAT allows. The performance of different techniques, when sized, maintained and operated effectively, are usually quoted in terms of abatement efficiency. However, even a high abatement efficiency on a gas stream with a very high odour concentration can still lead to large emissions of offensive odour. For odorous emissions therefore it may be more appropriate to consider the post abatement residual odour emission rate rather than the abatement efficiency.

Refer to IPPC Guidance Note H1 “Environmental assessment and appraisal of BAT” ([Reference 8](#)) for guidance on factors which should be considered in selecting/comparing different abatement techniques.

4.2.3 Overview of main abatement techniques

The following end-of-pipe abatement techniques are described in the following pages:

- **Adsorption** using activated carbon, zeolite, alumina
- **Dry chemical scrubbing** solid phase impregnated with chlorine dioxide or permanganate
- **Biological treatment** soil bed biofilters, non-soil biofilters - peat/heather, woodbark, compost - bioscrubbers
- **Absorption (scrubbing)** spray and packed towers, plate absorbers
- **Incineration** existing boiler plant, thermal, catalytic
- **Other techniques** odour modifying agents, condensation, plasma technology, catalytic iron filters and ozone and UV.

For all techniques it is important to ensure that the system is sufficiently well monitored to detect deviations from normal operating conditions. There are a number of suitable indicators, which could include, for example, operational parameters such as flow, temperature, pressure, or an indication of efficacy such as reactivity of scrubber liquors or monitoring of gas at the outlet. In addition, appropriate measures should be put into place to avoid causing odour annoyance in the event of a malfunction.

Defining a field of application for different abatement technologies is difficult, given the number of variables. The following figure defines where abatement techniques are typically used as a function of flowrate and concentration. Obviously the demarcations between technologies is not set, and other factors such as detailed gas composition and level of control required may play a very important role in the decision-making process.

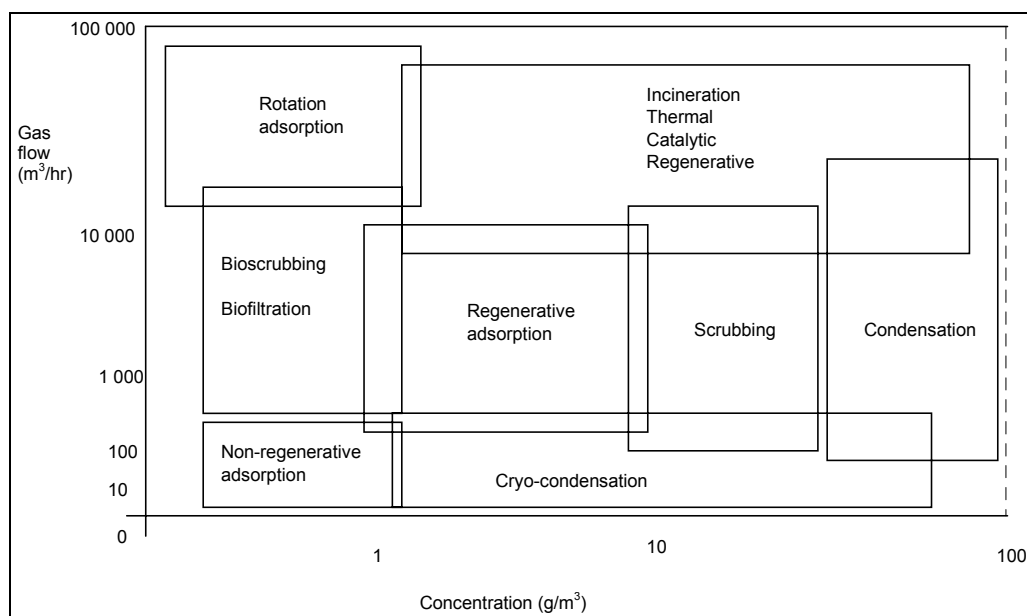

Figure 4.2: Generic guidance for the application of different abatement techniques as a function of flowrate and concentration
(Reference 14)

The following sections build upon information previously published in HMIP Technical Guidance Note A3 – “Pollution abatement technology for particulate and trace gas removal”.
(Reference 18).

4.2.4 Adsorption

The process of adsorption occurs when gas molecules are “captured and retained” on a solid surface (the adsorbent). There is a mass transfer of molecules from the bulk of gas to the gas-solid interface and diffusion through the pores of the solid until the molecule is finally adsorbed onto an internal surface. Some adsorbents preferentially adsorb specific chemical species, hence odorous components can be removed from gaseous streams by passing through a bed or filter of the appropriate adsorbent material.

The most commonly used adsorbent material is activated charcoal (carbon) as this has a large surface area and it reacts with a wide range of organic molecules. It is also relatively inexpensive. The adsorbent may be contained within a canister, filter or a bed through which the contaminated air stream is passed. The adsorptive capacity of the filter becomes progressively exhausted as the active sites on the adsorbent become occupied and it will have a finite life before the compounds start to “break through” the end of the filter. The point at which the filter becomes saturated, ie a vast majority of sites are occupied and efficiency is impaired, will be dependent upon a number of factors which include temperature, concentration of pollutants in the gas stream, humidity and gas velocity. At this point the adsorbent is either discarded and replaced or regenerated in situ.

Selection of the appropriate adsorbent for the particular application is critical to effectiveness. Although carbon is the most widely used, silica gel, zeolites and metal oxides tend to be used for polar compounds. These can be used in circumstances where high temperature or high moisture content preclude the use of activated carbon. Density and evenness of packing are also important factors as the gas stream will tend to find low resistance routes through the bed with a resulting drop in efficiency.

Many odorous compounds have low odour thresholds and the possibilities for regeneration may be limited because of the difficulties of cost-effectively regenerating the bed to the quality required for odour control.

Typical applications

Adsorption is an appropriate odour abatement technology for gas streams containing low concentrations of organic compounds. If used to abate high concentration (but low flow) gas streams, saturation will occur very quickly and the running costs will be correspondingly high. Typically, abatement efficiencies range from 90 to 99.9% removal and the post abatement residual odour can be as low as 100 to 400 ou/m³ - but both depend upon the compound(s) adsorbed.

Adsorbents can be used in the following ways:

- as the primary abatement method for ventilation air or process gas
- as a polishing stage on the outlet of another primary abatement technique
- to concentrate odorants on carbon prior to destruction by incineration or regeneration and destruction of the off gas (or use as a fuel)
- as a carrier for reactive agents - e.g. carbon can be impregnated with caustic to remove hydrogen sulphide.

Industrial applications:

- sewage treatment
 - odorants include - hydrogen sulphide, mercaptans, organic acids
- rendering - cooking (non sensibiles) and plant ventilation air
 - odorants include aldehydes, ketones, acids, alcohols, alkanes, dipropylsulphide.
- petrol stations
- manufacture of extruded plastic products
- food processing, e.g. ready meals. Odorants include sulphides, ketones, acids and alcohols.

ADSORPTION Selection and design considerations

Adsorbent selection

The most important design consideration is the selection of an appropriate adsorbent. This is largely dependent on the chemical nature of the gaseous stream. For the removal of many organic vapours activated carbon is the most commonly used adsorbent. The relative adsorptivity of commonly encountered odorants on activated carbon is shown in [Table 4.1](#) below.

Table 4.1: Relative adsorptivity on activated carbon

ADSORPTION
Selection and design considerations (cont)

High Capacity: adsorbs 20-50% of own weight		Satisfactory capacity: adsorbs 10-25% of own weight	Not highly adsorbed but may be sufficient under certain conditions.	Adsorption not satisfactory
Acetic acid	Isopropyl alcohol	Acetone	Acetaldehyde	Ethylene
Alcohol	Mercaptans	Acrolein	Amines	
Benzene	Ozone	Anaesthetics	Ammonia	
Body odours	Perfumes, cosmetics	Animal odours	Butane	
Butyl alcohol	Phenol	Chlorine	Formaldehyde	
Butyric acid	Pyridine	Diesel fumes	Propane	
Caprylic acid	Ripening fruits	Hydrogen sulphide		
Cigarette smoke	Toluene	Solvents in general	Consider on case-by-case basis.	
Cresol	Turpentine			
Disinfectants				
Ethyl acetate				
Gasoline				

Activated carbon can also be modified to enhance its performance (which also increases the cost) by:

1. impregnation or doping with chemicals to enhance adsorption capacity by reaction, for example carbon can be impregnated with caustic to remove hydrogen sulphide and with citric acid to remove ammonia
2. modification of the pore size within the activated carbon to enhance the physical attraction between the odorant and the adsorbent.

If polar molecules are to be adsorbed, the following adsorbents are typically more suitable than activated carbon:

- silica gel
- synthetic zeolites (molecular sieves)
- metal oxides.

The first two have a similar capacity to carbon and are often used to dehydrate gas streams. Metal oxides, such as activated alumina, are mainly used for the preferential adsorption of polar molecules such as carbon dioxide and sulphur dioxide.

Adsorptive capacity

The adsorptive capacity of the adsorbent depends on a number of factors. Adsorption is dependent on gas molecules reaching the internal pores of the adsorbent, hence the significant factors are:

- the concentration of the odorous molecules around the adsorbent material
- the surface area of the adsorbent
- the number of pores of appropriate size
- the characteristics of the odorous molecules (weight, polarity and shape)
- properties of adsorbent surface (polarity and shape of pores)
- equilibrium dynamics, e.g. competition of compounds for a place on the adsorbent.

Process Conditions

For the removal of volatile organic compounds (VOCs), ambient temperatures of about 15-40°C are generally recommended for adsorptive processes. If the temperature is too high desorption of previously adsorbed compounds may occur, and if too low the rate of adsorption reduces considerably. Adsorption also increases with high partial pressures. Humidity should be kept below 50% because adsorptivity is reduced at higher humidities (as water is adsorbed rather in preference to the odorous compound).

Impregnated adsorbents, such as activated carbon doped with citric acid, rely on chemical reaction and tend to be more efficient at humidities close to 100%. The high humidity is required to allow odorous gases to absorb into the water layer on the adsorber surface. Once in the water layer compounds then adsorb and react with the impregnated adsorbent. Higher temperatures are required to initiate the

**ADSORPTION
Selection and design considerations (cont)**

formation of the chemical complexes between odorous molecules and adsorbent and the rate of reaction increases with temperature.

If the pressure drop across the bed is too high, dusting and abrasion of the adsorbent particles and channelling due to their re-arrangement may occur. If the additional pressure drop can be tolerated, two beds in series give a high degree of removal and this arrangement provides additional protection as the first bed approaches then end of its life and becomes saturated.

Options for system configuration

There are three major types of adsorber system:

- *fixed bed unsteady-state adsorber* - contaminated gas is passed through a stationary bed of adsorbent
- *fluidised bed adsorber* - contaminated gas passes through a suspension of adsorbent
- *continuous moving bed adsorber* - adsorbent falls by gravity through a rising stream of contaminated gas.

Table 4.2: Comparison of different adsorbent systems

Adsorbent system	Advantages	Disadvantages
Fixed bed unsteady-state	Simple Economical Infrequent solids handling	With high quantities of contaminant a large portion of the adsorbent bed is saturated and therefore inactive. Where adsorbate flow rates are high, unduly large beds are required.
Fluidised bed and continuous moving bed	Multistage, continuous	Continuous handling and transport of solids is expensive. Systems must be large to be economical. Mechanical problems can arise with solids handling equipment. More attrition.

Fixed bed adsorbers, frequently in the form of filters or canisters, are by far the most commonly used for odorous gas streams, largely on account of the cost advantage and also convenience.

To optimise the efficiency of the adsorbent a number of carbon filters can be installed in series. These are designed to allow each carbon filter to be interchangeable so that the cleaner filters perform a polishing role and can be moved up to replace those at the inlet end which become saturated more rapidly.

Performance monitoring and maintenance

As the adsorbent becomes saturated the concentration of the odorous components in the discharge stream becomes unacceptable. The abatement efficiency of adsorbers may be determined by monitoring the odour concentration at the inlet and the outlet. Typically operators perform an olfactory assessment (sniff test) as the breakthrough point is approached, although any implications for the health and safety of the tester should be taken into account. Alternatively it may be possible to use colorimetric tubes or other means of testing for specific components. If the odorous gas stream is dusty the measurement of pressure drop across the bed would be appropriate. Where the breakthrough time is predictable, the operator may elect to change the adsorbent on a regular basis prior to breakthrough rather than to undertake day-by-day monitoring.

When spent, the adsorbent will need to be replaced or regenerated. Where operations are relatively small scale and adsorbent canisters or filters are used, it is often more cost effective to return them to the supplier for refilling.

Regeneration of saturated adsorbent can be undertaken by means of heating, steaming, gas stripping or vacuum stripping. Whilst large amounts of VOCs can be usefully recovered from adsorbent material, mixed odorants are frequently not regenerated for recovery because of the mixture of compounds present. Where there is no recovery value there may be potential for use as a fuel in a boiler or incinerator.

In the majority of cases, spent beds of adsorbent are replaced rather than regenerated because of the additional capital and operating costs of installing an adsorbent regeneration system and dealing with

**ADSORPTION
Performance
monitoring and
maintenance
(cont)**

the resulting gas stream. Consideration should be given to sending spent adsorbent for off-site regeneration where on-site regeneration is not feasible.

The cost of regeneration or disposal needs to be considered as part of the total operating costs of the system. The environmental disbenefits of disposal without regeneration will also need to be considered as part of the overall environmental impact in terms of the use of raw materials and creating a waste stream which effectively may simply transfer the emission from one environmental medium to another. It must also be remembered that adsorbed compounds can “flash-off” of spent carbon to atmosphere unless properly contained.

Where relevant, reference should be made to the relevant Process-specific Guidance Notes or Permit conditions for specific monitoring and associated record-keeping requirements.

**Other
considerations**

The following issues will need to be addressed in determining suitability for purpose, and may also have ramifications for on-going operating costs.

- Particulate material in the gas stream can cause clogging and/or attrition. Dust filters may need to be fitted up-stream.
- Odour will breakthrough once the adsorbent has been saturated or if other conditions such as temperature or humidity cannot be optimised. Channelling will also lead to early breakthrough.
- The various compounds in a gaseous mixture will frequently have differing adsorption rates. If some components are preferentially adsorbed, breakthrough may occur some considerable time before the saturation point is reached for other compounds. Two or more stages may be needed, each with different adsorptive properties.
- After many cycles of adsorption and desorption the adsorbent may lose its ability to be regenerated in situ. When this occurs external reactivation (usually by the supplier) or replacement (spent carbon is typically disposed of by landfill or incineration) is required.
- There is a risk of combustion within the bed if ketones are adsorbed onto activated carbon.

Summary

Table 4.3: Summary of advantages and disadvantages associated with adsorptive techniques

Adsorption Activated charcoal - alumina - zeolite	
Advantages	Disadvantages
<p>Depending on chemical species involved, efficiency can be in excess of 99%</p> <p>Depleted adsorbent can often be regenerated and reused (larger applications, may not be cost effective on smaller units)</p> <p>Smaller applications can make use of easily replaceable, cartridge-type units.</p> <p>Relatively low cost compared to some other systems.</p>	<p>High temperature and humidity may cause odour breakthrough.</p> <p>High particulate content may cause clogging of bed</p> <p>High concentrations of odorants will cause rapid saturation</p> <p>Efficiency will deteriorate over a period as the bed becomes saturated.</p> <p>Disposal required for waste adsorbent which cannot be regenerated (for whatever reason). Pollutants may flash off unless contained.</p> <p>Regeneration will produce a gas stream which will require abatement.</p> <p>Ancillary equipment may be needed to pre-condition the gas stream before the carbon bed/filter - this can add considerably to the cost.</p>

4.2.5 Dry chemical scrubbing

Dry chemical scrubbing is effectively a sub-set of adsorption; non-regenerative adsorption.

Dry chemical scrubbers are a relatively recent addition to the odour abatement market recently and typically consist of an oxidising chamber and a polishing stage.

- *Oxidising chamber* - contains a support material which is impregnated with oxidising material (e.g. chlorine dioxide, potassium permanganate etc.). The odorous gas passes up through the oxidising chamber where it is adsorbed and then oxidised to non-odorous by-products.
- *Polishing stage* - comprises activated carbon which is used to remove any un-oxidised odorous compounds.

Typical applications

Dry chemical scrubbers are ideal for extremely low flow, relatively high concentration odorous gas streams. They can be purchased as stand alone systems so that one unit can be installed next to one source - this is advantageous because there is no need for a complicated ducting system and hence, the overall price may be cheaper.

Summary

Table 4.4: Summary of advantages and disadvantages associated with dry scrubbing techniques

Dry Scrubbing e.g. solid phase impregnated with chlorine dioxide or potassium permanganate	
Advantages	Disadvantages
<ul style="list-style-type: none"> • relatively low cost • low maintenance • small plant footprint • complex ducting arrangements are not required 	Difficulties encountered with the technique <ul style="list-style-type: none"> • emission of oxidised products, e.g. chlorine. • washout of oxidising products possible, e.g. potassium permanganate, potassium iodide. • oxidising media lifespan, and therefore cost • specialist labour required for media replacement. • potential for low odour removal effectiveness because of high residual chemical odour. • not particularly suitable for high gas flowrates.

4.2.6 Biological techniques

Soil bed biofilters, non-soil biofilters - peat/heather, woodbark, compost biofilters, bioscrubbers

The phenomenon whereby some organic odorous compounds can be metabolised and consequently degraded by naturally-occurring micro-organisms into non-odorous reaction products is widely used as the basis for odour control devices. These micro-organisms are reasonably robust provided that there is a constant supply of carbon and oxygen. Typically, after a period of "settling in" the microbial population will undergo a degree of self-selection to adapt to the defined odorous gas stream.

Biological treatment falls into two basic categories:

- *Bio-filtration*: a biofilter typically consists of a large bed of soil (earth), compost or fibrous peat through which the malodorous air is passed.
- *Bio-absorption*: One form of bio absorber is a packed tower in which the packing material supports a microbial film (bioscrubber)

High efficiency (>99%) of odour reduction with minimal secondary pollution (wastes generated) can be achieved with a soil biofilter provided a suitable colony is established and maintained, although manufacturers are unlikely to provide guarantees in excess of 95%.

The residual post abatement odour concentration from an adequately sized biofilter where the feed stream variation is relatively low can be of the order of 100 to 400 ou/m³, depending on the biofilter medium used (the filter materials will also have an inherent odour). However the footprint is often large and a bio scrubber may have to be considered where space is at a premium.

The adaptation period of micro-organisms is slow in comparison to the fluctuations in many industrial processes and hence biofilters are best suited to processes with an output stream in which changes of concentration take place sufficiently slowly to allow the microbial population to adapt. They are also sensitive to changes in inlet temperature. Biological techniques are NOT suitable for batch processing or intermittent gas streams, seasonal activities etc. In view of the long period which is usually required for regeneration should the microbial population be destroyed, contingency plans will usually be required where the consequences of failure or poisoning would lead to an unacceptable odour emission. The nature of appropriate arrangements which constitute BAT will be installation specific.

Typical applications

Peat and heather biofilters have been used in a wide variety of applications and are broadly suited to those process types evolving large volumes of air at low to medium odour concentrations. Typically the life time of a biofilter, if maintained correctly, varies from three to five years. Types of operation where these have been used include:

- rendering plants
- maggot farms
- animal foodstuff producers
- perfumeries
- fine chemical and food/drink processes
- waste water treatment works.

Biofilters might also be considered for abating certain solvent emission, e.g. print works or coating plants, though their application in this area is not well established and suitability should be established prior to committing expenditure..

Bioabsorption is widely used on the continent for agricultural and chemical applications but take-up has been generally slow in the UK.

Biofilters are sometimes used as a "polishing stage" to treat the off-gas from an absorption tower (scrubber). The absorption stage can be used to remove substances which have potential to "poison" the biofilter.

Selection and design considerations

There are two basic types of bio-oxidation equipment:

- biofilters
 - soil based;
 - non soil based
- bioscrubbers.

**BIOLOGICAL
TECHNIQUES**
**Selection and
design
considerations
(cont)**

Biological abatement techniques will need an initial period of for the microbial population to become established but to work most effectively require relatively stable conditions. Such techniques are therefore not suited to treating gas streams that fluctuate in concentration, content or temperature to any great degree.

Performance is also temperature dependent to some degree (which will depend upon the resident population). Hence the efficiency may vary with seasonal temperature change although this may be offset by the temperature of the incoming gas.

The following sub-sections describe the two types of bio-oxidation equipment in more detail.

Soil biofilters

A soil biofilter consists of a moist layer of porous soil supporting a diverse and rich supply of bacteria and fungi, underlain by a network of perforated pipes through which the odorous air is passed. The air stream passes up through the soil and the microbes oxidise the odorous compounds in the air to less noxious/odorous substances. The treated air stream is then discharged from the surface of the filter. Some filters are enclosed or covered and the gas is discharged via a stack.

Selection and design considerations

Both non-soil biofilters and soil biofilters require water and a suitable matrix on which biological organisms can exist.

Soil biofilters have a more varied biological population which exists in a less controlled environment than non-soil biofilters and thus require relatively long residence times, typically 3 to 5 minutes. They therefore tend to be larger than non-soil biofilters and are best suited to locations where there is a comparatively large amount of available land.

The contaminated air is usually fed to the biofilter by means of perforated pipes set at right angles to the header pipe. The perforated pipes should be laid in a continuous layer of coarse gravel which will act as distributor and allow the contaminated air to flow uniformly through the biofilter. A soil depth of one metre is usually recommended and the soil should be open textured with a high organic content, e.g. sandy soil. Sometimes it is necessary to separate the air distribution system into sub systems to ensure uniform distribution (see [Figure 4.3](#)).

Performance monitoring and maintenance

Soil based biofilters should be irrigated (10 litres per square metre of biofilter per day, depending upon the season) to ensure that the soil remains moist, particularly during periods of low rainfall. Final treated effluent is sometimes used which has an added benefit of replenishing trace nutrients. However the nature of the effluent and any consequences of compounds becoming airborne should be considered. The nozzles of the irrigation system should be periodically checked for blockage.

A daily visual examination of the bed should be undertaken for cracks or holes where untreated gas may be escaping. The escape of untreated gas can often be detected by scorched vegetation in the vicinity of the crack/hole or sometimes can be heard as a high pitched whistle. Such events are almost always attributable to inadequate irrigation of the bed or to a fractured pipe.

It is good practice to carry out daily olfactometric assessment (sniff testing) at the filter outlet and other appropriate locations. Alternatively the appropriate colorimetric detection tube might be used for detection of specific compounds.

A vigorous growth of foliage is to be expected on the surface of the bed. This can help to remove nitrates and phosphates from the soil which may otherwise run off and can also help to prevent rapid drying out of the bed, particularly in dry conditions. The level of growth should not be so excessive as to prevent inspection of the bed. When cutting the foliage care must be taken not to damage the pipes underneath.

Where relevant, reference should be made to the appropriate Process-specific Guidance Note or Permit conditions for specific monitoring and associated record-keeping requirements.

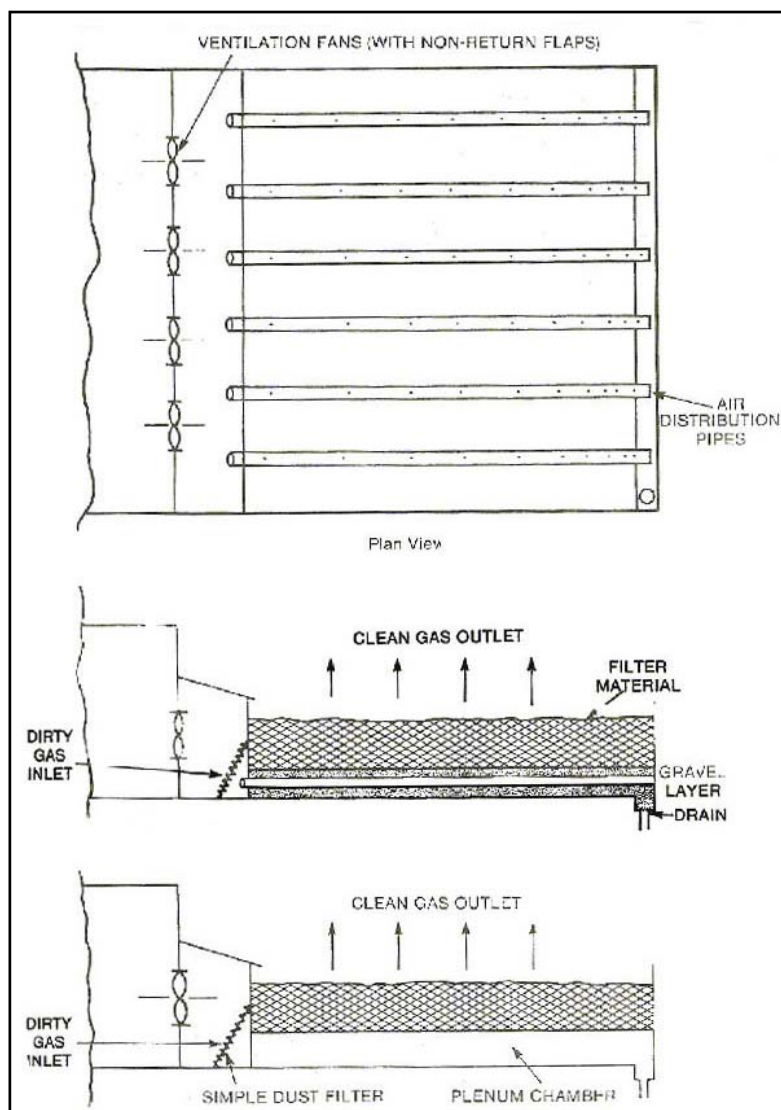

Figure 4.3: Schematic diagram of a biofilter

Summary of the issues associated with the technology:

- Biofilters take up a large amount of space. Sizes can vary between 1 500 to 7 500m².
- The bed may become blocked by compaction. Annual turning of the soil will help to minimise compaction.
- The bed may crack because of insufficient wetting. If cracks do occur, non uniform flow of odorous air through the bed will occur - the air will preferentially flow through the cracks to atmosphere, reducing residence time and odour removal efficiency.
- Distribution pipes may flood because of inadequate drainage or an increase in the level of the water table.
- Distribution pipes may become blocked because of the presence of fine particles. This will result in uneven air distribution throughout the biofilter.

**Non-soil
biofilters**

A non-soil biofilter is similar in principle to a soil biofilter, but the support material for the microbes is typically peat, heather, compost, seaweed, or wood bark. Efficiency can be up to 95%, ie soil biofilters can, under ideal conditions, can be more efficient than the non-soil variety.

Only those aspects on non-soil biofilters that are different from soil biofilters are described below:

**BIOLOGICAL
TECHNIQUES
Non-soil
biofilters
(cont)**Selection and design considerations

Many different types of media exist for non-soil biofilters; these include:

- woodchip
- peat plus a “stiffener material” (e.g. heather, polystyrene)
- composted domestic waste
- calcified seaweed.

The medium of choice has to:

- provide a damp environment for microbial activity
- provide trace nutrients.

Peat is the most commonly used material but if it is used alone without a supporting “stiffener” after a few months it will consolidate, resulting in a high pressure drop across the bed and a reduction in odour removal efficiency. To improve performance, the peat is mixed materials such as heather or coarse softwood chips which, in addition to providing the appropriate structure to prevent consolidation, also provide additional sites for microbes to inhabit.

The residence time required for a non-soil biofilter is typically 45 seconds for wood chip based filter beds and 60 seconds for peat/heather filter beds. Pilot-scale work is advisable to determine minimum residence time for a particular application.

The operational process is essentially oxidation and so intermediate products of biodegradation can be acidic. Taken together with the inherent acidity of peat based filters, the filter can become increasingly acidified which leads to a falling off of performance. Consequently, pH maintenance is sometimes required, particularly if the filter has been inoculated with a closely defined population of bacteria. The use of carbonated biomass can eliminate or reduce acid formation, for example, seaweed will act as a buffer against acidification.

Attention to nutrient levels is also required; too much biomass will lead to filter clogging and too little will reduce the efficiency of the filter. Many processes naturally provide the trace nutrients required (sometimes in excess) but where there are deficiencies commercial fertiliser can be used to make up the deficit.

Where possible biofilters should be covered to maintain a moist environment and to protect against the effects of frost as they are more susceptible to damage than soil filters.

In situations where the gas to be treated contains fatty acids or is dusty, it may be necessary to pre-treat the incoming gas. Typically fatty acids are found in the hot gaseous effluents of food factories.

Performance monitoring and maintenance

Abatement efficiency is assessed by monitoring the inlet and outlet gases. The assessment method will depend upon the compounds of interest, but olfactometry is usually the method most suited to mixtures of odorants.

Daily olfactometric assessment, irrigation and visual inspection requirements are the same as for soil filters.

At monthly intervals the pressure drop across the non-soil biofilter should be measured. Typically the pressure drop should be in the region of 35-60mm water however a drop of 100mm will indicate bed compaction whereupon the bed will need to be changed. It is good practice to turn over the bed of a non-soil biofilter at least once a year. Typically the life time of a biofilter, if maintained correctly, varies from three to five years.

Where relevant, reference should be made to the appropriate Process-specific Guidance Note or Permit conditions for specific monitoring and associated record-keeping requirements.

Summary of the issues associated with the technology

As for soil filters, but additionally:

- non-soil based biofilters will cease to function if they are allowed to dry out and they are very difficult to re-wet. Conversely, over watering should also be avoided otherwise the necessary microbes will be washed out of the bed. Typically, peat and heather bio-filters require approximately 60% moisture content to work well.

Bioscrubbers

The operational principles of bioscrubbers are the same as biofilters, although the configuration is different. The contaminated gas is passed up a tower against a countercurrent flow of water containing a population of microbes suitable for oxidising the odorous components of the gas. The tower is designed to contain packing material on which the microbes adhere to form a biological "mat".

Typical applications

In theory, a bioscrubber can be used whenever bio-oxidation is an appropriate solution and the solubility of the target species is high. When compared to biofiltration it has the advantages of taking up less land area and of discharging the treated gas at height rather than at ground level. The technique has however not been widely used in the UK when compared to continental Europe where bioscrubbing is widely used in agricultural and chemical applications.

Selection and design considerations

Bioscrubbers are more energy intensive than biofilters since both water and air are being recirculated. The scrubbing tower should be designed to provide a contact time of about 1 second, depending on the composition of the inlet gas.

Performance monitoring and maintenance

As with biofilters, it is good practice to carry out daily olfactory assessments at the outlet and other appropriate locations. The health and safety implications for the tester need to be considered. Where the outlet is at a height permanently installed arrangements consisting of a tube and funnel have been successfully used to allow testing at ground level, although a small fan may be needed to move the air through the tube.

Assessment of efficiency can be undertaken by means of undertaking chemical analysis or olfactometry on inlet and outlet gases.

Regular monitoring of parameters such as pH, biological oxygen demand (BOD), flow and pressure drop will need to be undertaken as it is important to maintain steady-state conditions. It is also important to inspect regularly for fouling or excessive biomass. Microbes can break away from the support material and foul pumps and nozzles. Periodic monitoring of the microbial activity is also needed to ensure that the population is sufficiently high.

Where relevant, reference should be made to the appropriate Process-specific Guidance Note or Permit conditions for specific monitoring and associated record-keeping requirements.

Summary of the issues associated with the technology

- Biomass may build up within the tower blocking the circulating water. Easy access to remove biomass is required.
- Odour can be emitted from the liquid circulation hold-up tanks unless adequately contained. If chemicals are used to remove the odour care must be taken to ensure that they do not poison the microbes within the tower.
- Microbes can be "carried over" by the air stream to the exhaust and will be lost. Microbial activity needs to be continuously measured and occasionally additional microbes will need to be added to the tower.

Trickle-bed filters

Trickle-bed filters are a hybrid of biofilters and bioscrubbers. Contaminated gas passes through a packed bed which supports an active microbial film. The support material may be either a traditional material (e.g. heather) or an inert substance. Water from a sump is sprayed on top of the bed and is continuously re-circulated. The gas flow being treated may be either counter-current (opposite directions) or concurrent (same direction) to the water flow.

**Summary
(Biological
techniques)**

Table 4.5: Summary of advantages and disadvantages associated with biological techniques

Biological treatment Biofiltration – bio-absorption (bioscrubbing)	
Advantages	Disadvantages
Biofilters	
<p>Peat and heather filters can be up to 95% efficient, whilst soil filters can be >99% efficient</p> <p>Relatively inexpensive to install and maintain compared to other abatement options</p>	<p>Large land area required for biofilters, although tower versions are available (at additional cost)</p> <p>Soil biofilters have higher running costs than peat/heather biofilters</p> <p>Unsuitable for treatment of gases with very high odour concentrations</p> <p>Input parameters are critical to obtain higher efficiencies; temperature, pH and humidity must be controlled within narrow limits. Very dependent upon ambient conditions and regular irrigation is needed, particularly in dry weather</p> <p>Additional nutrients may be required to support the microbial population. Back-up of some form is required in case of poisoning of population</p> <p>Adaptation to the input concentration and composition is slow, hence not suitable for fluctuating airstreams or batch processes.</p> <p>Monitoring can be difficult unless covered (can measure at the outlet)</p> <p>Size often leads to poor maintenance</p>
Bioabsorption	
<p>Bioscrubbers can be >99% efficient</p> <p>Replacement of support medium not required</p> <p>Relatively small footprint compared to biofilters</p>	<p>Slow to respond to change in odour levels</p> <p>Unsuitable for treatment of gas streams with high odour concentration (approx 100ppm H₂S)</p> <p>The removal efficiency is limited by ambient conditions</p> <p>Sloughing of the biomass can occur - microbes break away from the inert support</p> <p>More expensive to run than a biofilter</p>

4.2.7 Absorption (scrubbing)

Absorption is a process involving mass transfer between a soluble gas and a liquid solvent in a gas-liquid contacting device (a “scrubber”). The liquid phase is generally recirculated with a small amount being continually being bled off and the same amount of fresh reagent being introduced. The primary requirement is to bring the contaminated air into contact with the liquid. The odorous components of a gas stream are transferred to the liquid phase where a chemical reaction takes place. Water is often used as a scrubbing liquor and removal efficiency is typically 90%. To increase absorber efficiency, various reagents are added to the scrubbing water to remove specific odorous compounds, sometimes in separate scrubbing stages. Typically acidic or alkaline gases are absorbed into pH controlled solutions, whilst other odours are absorbed into appropriate chemical solutions according to composition. Oxidants (often chlorine based) are frequently used for aldehyde and ketone control.

The efficiency of mass transfer depends on several factors:

- solubility of odorous component in the liquid phase (see [Table 4.7](#))
- gas - liquid contact time
- contact area.

Odorous compounds can be associated with the particulate fraction of an airstream and the liquid also serves to remove entrained particulate from the gas stream. This technique is often referred to as “wet scrubbing”.

Several types of absorber are available, all of which are designed to maximise gas liquid contact usually by countercurrent flow, and to handle large volumes of air with little pressure drop. Packed towers are often used for odour abatement as they increase the gas-liquid contacting area.

Scrubbing is often the best method for treating large gas flows containing low to medium concentrations of odorous compounds. This should be compared with incineration where the requirement to treat large volumes of air can prove to be prohibitively expensive. Large flows are generally considered to be those in excess of 2m–3m/s. Suitable odour concentrations would typically range from several thousand to a few hundred thousand of odour units per cubic metre. Higher concentrations are not generally suited to this technology. In general, the types of application tend to be those for which biological treatment is also a possibility, although marginally higher concentrations can generally be handled by absorption.

There are a number of issues associated with the use of chemical reagents. The use of oxidants can sometimes lead to the formation of odorous compounds in the scrubber which are subsequently carried over to atmosphere, and poor effluent management can create odour sources. Therefore the absorber, if poorly designed and controlled, can become a secondary source of odour. It should be possible to design a system to maintain a residual post-treatment odour emission of below 1,000 ou_E m³.

The nature of the wastes created and their disposal will need to be considered as part of the total environmental impact of the technology. A gas stream which contains high levels of water vapour can result in larger volumes of effluent than would otherwise be the case; a modified design may be necessary.

Catalytic scrubbing has been developed relatively recently in response to the desirability of avoiding the need for a number of scrubbing stages, each with a different reagent. Catalytic scrubbing requires only a single absorption unit within which hypochlorite scrubbing is catalytically enhanced by a nickel oxide catalyst held on an alumina support. This has been used to oxidise a wide range of compounds.

Typical applications

A fairly wide range of odorous compounds can be treated by absorption; suitability relies on the reactivity of the compound with the selected chemical reagent. Specificity can be a problem - such that several reagents may be needed for high removal efficiency. Some odorous compounds may be generated by the scrubbing process, for example by chlorinating agents and will need to be removed in an additional stage.

The technique has been used with varying degrees of success for a number of different odour emissions. These include the emissions from rendering plants, maggot farms, tanning, vegetable hydrolysis, tobacco processing, pharmaceutical production, fatty acids, waste water works, dye-stuffs, amines, phenolic resins and methyl methacrylate. The techniques is also suitable for post-incineration gas cleaning if acidic gases have been produced.

ABSORPTION
Typical applications (cont)

The selection of chemical reagents for the scrubber liquor is dependent upon the nature of the odorants in the contaminated air/process gases to be treated in the absorber. Although it is conceivable that a great many chemicals have a potential application in odour control, in practice the choice tends to be made from a rather limited selection, listed below: there may also be benefit in the addition of surfactants to the liquor to modify the effective surface area and hence aid the adsorptive process.

Most of the commonly used reagents belong to two broad classes:

- (i) neutralising compounds
- (ii) oxidising agents.

Some of the more common from amongst these are summarised in [Table 4.6](#) below.

Table 4.6: Some commonly-used reagents

Reagent	Comments
Neutralising compounds	
Water	Water is suitable for absorbing soluble acidic gases such as: hydrogen chloride, hydrogen fluoride, silicon hexafluoride, ammonia.
Sulphuric and other acids, sodium hydroxide or other alkalis	<p>Acid solutions may be needed for the absorption of very soluble basic gases to very low levels, amines</p> <p>Alkaline solutions are suitable for absorbing less soluble acidic gases such as: Sulphur dioxide, hydrogen sulphide, chlorine, very soluble acidic gases to very low levels</p> <p>The reactions are reversible upon dilution or neutralisation such that odorants may be desorbed from liquid effluent, for example in sewerage systems. For this reason these reagents are often used in combination with an oxidising agent. At high pH, atmospheric CO₂ will be absorbed</p>
Oxidising agents	
Potassium permanganate	Most commonly used in neutral or alkaline solution although manganese dioxide is formed as a by-product and will precipitate out. The colour can be used as an indication that the reagent is still active
Hypochlorite (can be purchased as a solution or generated by electrolysis of a sodium chloride solution).	<p>pH <2: chlorine water pH 2-6: hypochlorous acid pH >6: hypochlorite</p> <p>Commonly used at high pH, but can also be effective when used in moderately acid solution. It will give off an odour even when odour-free air is passed through, particularly at low pH. Some compounds can become chlorinated; the derivatives can have very unpleasant odours</p>
Chlorine dioxide (can be purchased as a stabilised solution)	Chlorinates some odorants, though fewer than chlorine. Handling difficulties need consideration in terms of safety implications
Ozone (electrically generated on site)	Generally used in the gas phase though the presence of water seems to be beneficial. Low toxicity threshold
Hydrogen peroxide	No undesirable byproducts are formed, although it is arguably less effective than some other oxidants
Sodium metabisulphite	Specific reagent for aldehydes and ketones

Selection of an appropriate gas absorber

The driving force for odour removal by absorption is the difference between the partial pressure of the soluble gas in the gas mixture and the vapour pressure of the solute gas in the liquid film in contact with the gas. Mass transfer occurs by molecular diffusion across the gas/liquid interface.

Gas absorption is a rate process and consequently the concentration gradient (reaction driving force) and the surface area of contact between the liquid and gaseous phases are crucial design parameters.

There are several factors which determine the most appropriate type of absorber to be used:

- properties of the incoming gas stream (which determine the properties of the reagent required)
- required abatement efficiency (hence contact surface area and concentration gradient)
- energy efficiency.

ABSORPTION
Selection of an
appropriate gas
absorber
(cont)

The selection of an appropriate absorbing medium is dependent upon the properties of the odorous compounds.

Table 4.7: Summary of suitable absorption medium for different pollutant common odorant species

Pollutant	Suitable Absorption Medium
<u>Acid gases</u> Hydrogen chloride Hydrogen fluoride Sulphur dioxide	Water, sodium sulphite solution, alkaline solutions/slurries
<u>Odorants</u> Hydrogen sulphide	Absorbed at high pH Oxidise particularly at high pH
Mercaptans	Absorbed at high pH Can be oxidised particularly at high pH Weak oxidants may oxidise to odorous disulphide
Sulphides	Can be oxidised. The use of a catalyst should be considered.
Disulphides	Can be oxidised; hypochlorous acid more effective than hypochlorite
Aldehydes	React with bisulphite Oxidise particularly at high pH
Ketones	React with bisulphite (but less well than aldehydes) Oxidise particularly at high pH
Fatty acids	Soluble in water or slightly alkaline solution
Amines	Soluble in slightly acid solution May be chlorinated to form strongly odorous reaction products Can be oxidised The use of a catalyst should be considered
Unsaturated compounds	Can be oxidised Absorbed at high pH
Phenols	May be chlorinated

Organic solvents can be used to absorb organic species but this can lead to the generation of sludge or separation of the solute from the solvent. In almost all cases organic solvents as absorbing media are not used to remove odorous components - different abatement techniques are usually chosen, e.g. adsorption or incineration.

There are five generic types of absorber.

1. Spray tower

Liquid enters the top of the tower via spray nozzles as the dirty gas stream passes up the tower. Spray scrubbers can be designed such that the gas flow is counter-current (gas flows in the opposite direction to liquid flow), concurrent (gas and liquid flow in the same direction) or cross current (gas and liquid flow are at right angles to each other)

Liquid droplets produced by the spray nozzles fall down the tower through a rising stream of dirty gas. Gas/liquid contact at the droplet surface enables mass transfer to occur.

Typical applications

The technology has been successfully used by various sectors of the chemical industry for absorbing acid gases and odours, for ammonia hydrolysis and for particle abatement.

Selection and design considerations

Spray towers are less effective for trace gas removal than packed bed absorbers but will tolerate dusty gas streams, removing particulate into the aqueous phase.

ABSORPTION
Selection of an
appropriate gas
absorber
(cont)

Efficiency of mass transfer increases as the liquid: gas ratio increases and several consecutive stages give enhanced adsorption efficiency.

Droplet diameter and liquid distribution are critical design parameters. Large droplets yield a low surface area for mass transfer but fine droplets may be entrained in the gas stream and be carried out of the tower such that a mist eliminator may be required. Typical droplet diameters are 200-600 μ m.

The pressure drop across a spray tower is usually in the range of 25-50mm water (0.25-0.5kPa) and typically liquid: gas ratios are 4-13 litres liquid/m³ gas.

Summary of issues associated with the technology

- Spray nozzles may block, particularly as the amount of entrained particulate increases (a filtering mechanism may be needed). This will change the liquid distribution in the tower and lower efficiency.
- High removal efficiencies cannot be achieved as the contact time is lower than occurs in a packed tower and there is less surface area available for transfer.
- Droplet carry-over can occur.

2. Plate absorbers

Plate absorbers consist of a vertical tower with several horizontal perforated trays (sieve plates) stacked in the body of the tower. Baffles are situated a short distance above the apertures in the plates. Liquid enters the top of the tower and flows along each of the trays successively. Dirty gas enters the bottom of the tower and flows upwards, passing through the perforations in the plates. The velocity of the gas is sufficient to prevent liquid seepage through the perforations.

Typical applications

Plate absorbers are effective for trace gas removal and particle collection. The technology has been successfully used in the chemical industry and industrial heating plant for the absorption of acids (in water), SO₂ (using sodium sulphite) and odours. They have also been used to abate odours from animal feed mills.

Selection and design considerations

Absorption efficiency can be increased by adding more plates to the absorber (increasing tower height) and by increasing liquid flow rate. Plate absorbers can operate at higher liquid flow rates than packed towers and are able to tolerate fluctuations in gas flow and temperature.

Absorption efficiency increases as pressure drop across a plate increases. Low outlet emissions can be achieved as the final gas liquid interface is between fresh liquid and comparatively clean gas.

Summary of issues associated with the technology

- Scaling with subsequent hindrance to even gas flow can be a problem. Plate absorbers are therefore not suitable for use with slurries, e.g. lime.
- Plate absorbers are not suitable for use with foaming liquids.

3. Packed bed absorbers

Packed bed adsorbers are the mostly commonly used type of absorber for the treatment of odorous releases. They consist of an outer shell containing a bed of packing material on support grids, liquid distributors, gas and liquid inlets and outlets and a mist eliminator. The absorbers are designed so that liquid is distributed continuously over the packing material forming a film which provides a large surface areas for gas/liquid contact. The contaminated gas flow through the packed bed can be either countercurrent (gas flows in opposite direction to liquid flow), concurrent (gas and liquid flow in the same direction) or cross current (gas and liquid flows are at right angles to each other).

Typical applications

Packed tower absorbers, with the appropriate reagents, have been successfully used for absorbing acid gases and odours from boiler flue gases, chemical, food, metallurgical and petroleum processes. Applicability is potentially wide with appropriate choice of reagents.

ABSORPTION
Selection of an
appropriate gas
absorber
(cont)

Selection and design considerations

Packed towers allow better gas-liquid contact and hence higher efficiencies are achievable than other designs. Packed towers are generally the preferred type of gas absorber for treating odorous gas streams.

The level of maintenance is also relatively low as this design is more tolerant of nozzle blocking; even if some nozzles block, gas-liquid contact will remain relatively large. The pressure drop is relatively low (typically about 50-75mm water).

There are various types of packing materials available which can be packed in random or in a regular arrangement. These are designed to maximise surface area whilst minimising pressure and risk of fouling.

Counter-current packed bed absorbers maximise the driving force for absorption because gas leaving the packed bed encounters fresh absorbing liquid. The liquid flowrate in counter-current packed absorbers is limited by the possibility of flooding. Concurrent and cross current designs are mainly used in systems where the absorption reactions are rapid. These absorbers have the advantage that they are less susceptible to plugging by particles and operate at lower pressure drops. Cross current gas absorbers operate at low liquid:gas ratios. The choice of cross flow scrubber is usually made when the height of the unit is of greater concern than the plot area.

Summary of issues associated with the technology

- Packed towers tend to be relatively tall; typically a diameter of 1.5m and a height of 7m is required to accommodate a flow of 1m³/s. The height of the unit is a function of efficiency, so very high removal efficiencies may lead to tall units, e.g. 10-12m.
- This type of scrubber is likely to be more than twice as expensive as a spray absorber.
- Packed towers are not suitable for treating gases containing high concentrations of particles - particles cause plugging of the packed bed. In some cases it may be necessary to install a separate particulate abatement device upstream.
- Residues and precipitates can build up within the tower depending on the liquids used as well as upon particulate concentration, and are more difficult to flush out than other scrubber designs.

4. Moving bed absorbers

Moving bed scrubbers consist of zones of mobile packing (usually plastic or glass sphere) where gas and scrubbing liquor can mix. The vessel shell consists of support grids on which the packing material is placed, inlets and outlets for gas and scrubbing liquors and a mist eliminator. Moving bed absorbers provide a large surface area and produce intimate mixing of gas and liquid for good mass transfer - due to the agitation and turbulence in the moving bed.

Typical Applications

Moving bed scrubbers are suitable for simultaneous removal of trace gases and particulate material.

They have been successfully used for trace gas removal (sulphur dioxide, hydrogen fluoride and odours) and particle collection in the metallurgical, chemical and food industries, power generation, sintering, mineral processing and waste industries.

5. Fibrous packing absorbers

Fibrous packing scrubbers are a sub group of packed tower scrubbers, comprising a chamber with a gas inlet and outlet which contains a mat of fibrous packing. Depending upon the application, the fibrous packing is either sprayed continuously or intermittently with liquid. The units may be designed for horizontal or vertical gas flow and typical fibre materials are glass, plastic and steel. They are relatively inexpensive, exert a low pressure drop and are capable of treating up to 50% more gas for a given size than a conventional packed tower.

Typical applications

The chemical, metallurgical and electronics industry have used this type of absorber to remove acidic components and organic/inorganic compounds from contaminated air streams.

Selection and design conditions

The efficiency per unit energy consumed is better for fibre packed absorbers than for packed bed absorbers. Efficiency for trace gas removal is typically 90% and depends on gas and liquid rate, fibre diameter, cell thickness and liquid distribution.

Summary of issues associated with the technology

- This type of absorber is prone to blockage by particulates or adventitious growth of biomass within the fibrous mat
- Blockage of spray nozzles can be a problem.

**ABSORPTION
Performance
monitoring and
maintenance –
all types**

Abatement efficiency can be determined by undertaking periodic chemical analysis or olfactometry on inlet and outlet gases. It is sometime possible to monitor continuously for a specific component of the gas stream but where a mixture of compounds is present it is frequently more effective to carry out daily olfactory tests ("sniff testing"). On some installations this has been successfully undertaken using an inverted funnel in the top of the stack on the end of a length of tubing which is attached to the outside of the stack down to a height at which testing can be undertaken. A small fan may be needed to move the air down the tube. This is obviously not suitable where harmful substances are present in the gas stream and a risk assessment should be undertaken before such testing commences. Continuous monitoring of operational parameters which represent the efficiency of odour removal, for example pH, can also be undertaken. In addition, parameters such as flow rates, pressure drop, reagent usage and temperature should also be recorded. Gas temperatures of up to 70°C can be tolerated, but at more elevated temperatures, product solubility may change, particulate production may occur and downstream condensation may become a problem.

Regular inspection should be undertaken for blockage and fouling of spray jets and packing (large scale fouling will generally manifest itself through increased back pressure on reagent supply lines and in increased pressure drop across the scrubber)

Where relevant, reference should be made to the appropriate Process-specific Guidance Note or Permit conditions for specific monitoring and associated record-keeping requirements.

Enhanced catalytic absorption

**Related
absorption
technologies**

Where a number of odorous compounds are present in a gas stream which require different reagents for absorption, or where, for example, chlorinated by-products are formed, a two or three stage scrubber may be needed. For example:

Stage 1 - absorber uses dilute sulphuric acid to remove amines and basic odours.

Stage 2 - alkaline sodium hypochlorite is used for the main oxidation process.

Stage 3 - dilute sodium hydroxide is used to remove any chlorine and reaction by-products emitted in the second stage.

In most situations the process works well, but chemical consumption can be considerable. The removal efficiency can vary, but typically >99.5% can be achieved. Odours which do not react rapidly with acid or alkali are not affected.

Catalytic scrubbing was developed in order to combine several stages into a single absorption unit.

The use of hypochlorite scrubbing in conjunction with a nickel oxide catalyst on an alumina support has been found to oxidise sulphides, amines, amides, alcohols, aldehydes, ketones, phenols, carboxylates, chlorinated hydrocarbons plus unsaturated and aromatic hydrocarbons (Hancock 1990-96, Unpublished data).

The catalytic reaction increases oxidation rates and suppresses chlorine and chlorine by-product formation. Thus the need to acid pre-scrub and caustic post-scrub is removed, although an acid pre-scrub will be used for economic reasons if levels of ammonia and amines are high (above 20-30ppm as a general rule).

Summary

Table 4.8: Summary of advantages and disadvantages associated with absorptive techniques

Absorption (scrubbing) Packed tower - plate tower - spray tower - moving bed	
Advantages	Disadvantages
<p>Can handle large volumes of air</p> <p>Efficiency >90%. (2 stage scrubber) – water Efficiency >99% - chemical</p> <p>Automatic dosing can allow for rapid reaction to presence of peaks in concentration, provided these are not too acute</p>	<p>Concentration of contaminants may require pre-dilution with clean air</p> <p>Chemical reagents needed unless dealing with water-soluble compounds</p> <p>Fairly specific; reagents must be matched to nature of contaminants. A multi-stage scrubber may be needed to deal with a stream containing, e.g. acidic and basic components. This increases the cost and complexity.</p> <p>Scaling and corrosion can be a problem, particularly when chemical reagents are used.</p> <p>Salt formation (often in the form of a gel) can block pumps. Salts may also block packed scrubber systems with the subsequent formation of preferential routes for liquor through the packing, with adverse results. Maintenance requirements may consequently be quite high.</p> <p>Use of chemicals can be high - careful process monitoring and control is required.</p> <p>Produces a liquid waste requiring disposal</p> <p>Particulates can cause blockages in packed towers.</p> <p>A mist eliminator may be required to prevent carry over of droplets.</p>
Catalytic scrubbing Packed tower	
Advantages	Disadvantages
<p>Acid scrubbing may not be required</p> <p>Total odour control in a single packed tower is possible</p> <p>High odour removal efficiency for organic odorants.</p>	<p>Potential for catalyst fouling.</p> <p>Does not remove insoluble organic odours.</p> <p>At high concentrations of basic odours, acid scrubbers may be more cost effective</p>

4.2.8 Incineration

Thermal oxidation techniques can be used for the effective destruction of odorous compounds. At present there are two basic techniques available; thermal incineration and catalytic incineration.

(a) *Thermal incineration*

Thermal incineration is the process of oxidation of combustible gases and odorants in a waste stream by heating the odorous air with air or oxygen to a high temperature in a furnace. If the combustion is complete and the odorants are organic compounds, the end products will be carbon dioxide, water and oxides of nitrogen. Sulphur dioxide will be present if the emission or fuel contains sulphur.

Typically, temperatures of 650 to 800 °C are required for effective destruction in a well-designed thermal incinerator, although existing boilers or furnaces can often be adapted for the subsidiary role of odour abatement. There are, however several potential difficulties which will need to be considered before committing to this option. These are outlined later in this section.

(b) *Catalytic incineration*

Catalytic incineration performs the same destructive oxidation of odorous substances but at a lower temperature, typically 350 to 400 °C, hence fuel consumption is lower. The oxidation reaction takes place on the surface of the catalyst rather than in free air. Typical catalyst materials are platinum, palladium, rhodium, or copper chromate. Catalysts can be subject to "poisoning" and must therefore be chosen with regard to the nature of the gas stream if they are to perform adequately and cost effectively.

Typical applications

Incineration can be applied almost universally to odour control because all organic odorants can be oxidised at high temperature, whereas the application of other methods is more specific. The main limiting factor is cost although there can be potential to minimise fuel usage where the waste gas stream has a high calorific value, and also potential to recover heat. Incineration tends to be used where odour concentrations are high. Small scale installations are available.

Thermal incineration has been used to successfully treat high odour concentration gas streams in many industrial applications, for example animal rendering plant, blood drying plant, barley roasting and for VOC abatement.

Catalytic incineration is an appropriate odour abatement technique when odour concentration is high and there is little or no particulate matter. Abatement efficiencies of 99.5% are normally achieved. However, if measured in terms of odour removal efficiency, the efficiency may be lower because the odour in the dirty gas stream will generally be substituted for an odour of combustion products, although of much lower concentration. A subjective test of the relative offensiveness of the input and output streams is useful in assessing the degree of success.

Catalytic incinerators have been successfully used for controlling the emissions of odour and VOCs from many industrial processes including animal rendering, plastic processing, coffee roasting, paint spraying, synthetic rubber manufacture and oil refining.

Selection and design considerations

The factors affecting choice are:

- capital cost
- operating cost
- nature of the odorous gas stream
- fuel availability
- available space.

**Thermal
incineration**

Rapid oxidation of odours occurs if the gas temperature is typically in the range of 750-800 °C. Complete combustion is dependent upon uniform mixing of fuel, the odorous gas stream and combustion air. The configuration of burner, mixer and combustion chamber are important to effective mixing.

Burner - fuel is burnt with clean air or with part of the contaminated air to produce a flame at a temperature of 1,500 °C.

Mixer - the remainder of the contaminated air is mixed with hot gas from the flame to bring it to a uniform temperature.

Combustion chamber - the gases are held at this temperature until oxidation has been completed (typically 0.5-1s).

Other selection and design considerations for incineration systems include gas pre-treatment and the potential for heat recovery.

Pre-treatment

Before odorous air is fed to the incinerator it may require some form of pre-treatment to:

- condense water vapour from a wet gas - this reduces fuel requirements and minimises corrosion problems
- remove solid and liquid contaminants - to minimise risk of fouling and corrosion
- preheat the incoming gas - which reduces fuel requirements.

Heat recovery

At present, there are two types of heat recovery system which might be coupled to a thermal incinerator in order to reduce running costs while still achieving acceptable odour reduction efficiency - recuperative and regenerative.

- **Recuperative** - the off-gas from the incinerator is used to pre-heat the incoming gas stream, thus reducing the amount of energy required to heat gases in the incinerator. This type of system is particularly suitable for gas streams of comparatively low flow rate and high levels of odour. 50-80% heat recovery is generally achieved.
- **Regenerative** - off-gas from the incinerator passes through several ceramic bed heat exchangers which are used to pre-heat the incoming gas stream. Oxidation of the off-gas also continues in the ceramic beds. The system is operated so that the beds alternate between heating, cooling and purging. This type of system is particularly suitable for gas streams of comparatively high flow rate (up to 40m³/s) containing lower odour concentrations; 80-95% heat recovery is generally achieved. This system provides better heat recovery but there is a danger of odorous gas contaminating the oxidised gases, hence the requirement for the purging step.

There is also the potential for secondary heat recovery, e.g. to obtain hot water, space heating etc. using both systems.

Typical applications

Almost universal application to odour control is possible because all organic odours can be oxidised at high temperature, whereas the application of other methods is more restricted. Cost is frequently the limiting factor. It is more cost effective if the gas stream has some calorific value, thus reducing the requirement for secondary fuel.

Performance monitoring and maintenance

It is important to refer to any relevant process-specific guidance notes or permit/licence conditions for specific monitoring and associated record-keeping requirements.

Continuous monitoring for carbon dioxide and/or oxygen, carbon monoxide and oxides of nitrogen in the effluent gas stream is generally required. There is also a requirement that temperature is measured as a means of monitoring combustion conditions. Sampling and analysis techniques suitable for high temperatures are required.

Abatement efficiency can be determined directly by monitoring odour concentration before and after the incinerator.

Summary of issues associated with the technology

- Capital and operating costs are high when compared to other forms of odour abatement, although incineration may be the only suitable technique available for effective treatment of gas streams with a high concentration of odorants.

**Thermal
incineration
(cont)**

- Any compound containing sulphur or chlorine atoms will generate sulphur dioxide (which is odorous) or acidic hydrogen chloride emissions and further treatment of the exhaust gas may be required.
- Burners need to be inspected regularly to ensure that there are no deposits. If deposits are a problem then pre-treatment of the incoming gas stream may be necessary.
- Sooty emissions and odour can arise if effective regular maintenance is not undertaken.
- Air moving fans may also be susceptible to damage from dust loading and should be fitted downstream of dust removal equipment.

Related thermal technologies*Kilns and boilers*

Existing kilns, furnaces and boilers can sometimes be used to incinerate odours where the temperatures and residence times lie within the appropriate range. This becomes an attractive choice if a kiln/boiler is already on site and particularly so if the boiler can be incorporated into the design stage.

Reference should be made to the appropriate Sector-specific Guidance Notes or Permit conditions for specific requirements or exclusions.

There are a number of plants in the UK handling animal products that use steam raising boilers as their primary form of combustion to treat process gas emissions. The technique has the ability to destroy the smell, but replaces it with a typical boiler stack emission odour. The disadvantages of this approach are that a secondary combustion unit may need to be on-stand-by in case the main boiler fails.

Combined heat and power plants have been used to treat odour emissions arising from starch production and they have also been used to treat the high sulphide content of mineral oil absorber emissions arising from rape seed oil extraction.

There are however several potential difficulties:

- not all boilers or kilns work for 24hrs/day, and hence they may not be able to treat a continuous odour emission all the time
- the destruction of odorous compounds requires a steady conditions of temperature and flow, whereas steam-raising boilers or furnaces may be subject to fluctuation as the loading demands change
- the flow rate or temperature profile may not be suitable without major changes
- materials of construction may not be able to withstand the corrosive effects of nitrogen or sulphur compounds.

Silica bed incinerators

Silica bed incinerators consist of a bed of sand with embedded heating elements and gas distribution boxes for inlet and outlet gas flows. The sand is initially heated by a heating element and as the dirty gas stream passes through the bed, it is heated and ignites. The heat of combustion is absorbed by the sand as the clean gas leaves the incinerator. Frequently, the direction of air flow is reversed to maintain a uniform temperature distribution across the bed.

This system can only be used for gas streams containing high concentrations of solvents or organics.

Some care must be taken with silica beds where the inlet gas position alternates from above to below (or vice versa) the combustion zone. It is possible for "puffs" of untreated odour to by-pass the oxidation unit for short periods of time and to be released untreated.

**Catalytic
incineration**

Catalytic incineration is similar to thermal incineration, the main difference being that the oxidation reaction takes place on the surface of the catalyst rather than in free air. The use of a catalyst allows the same degree of combustion completeness to be achieved at lower operating temperatures and hence lower fuel consumption. There is also a physical size advantage in that the footprint of catalytic incinerators tends to be smaller.

The dirty gas stream enters the unit and is preheated in a heat exchanger. A burner heats the stream which feeds to the catalyst section where odorous contaminants and oxygen diffuse from the air stream and are adsorbed onto the catalyst surface. Oxidation takes place and the products are desorbed back into the gas stream. The catalytic reaction is temperature dependent and for efficient operation the required temperature is typically between 350 - 400 °C. The exhaust gas is then passed through a heat exchanger which is used to preheat the incoming air stream.

**Catalytic
incineration
(cont)**

Figure 4.4: Schematic diagram of a catalytic incinerator

Typical applications

Catalytic incineration is an appropriate odour abatement technique when odour concentration is high and there is little or no particulate matter. Abatement efficiencies of >95% are normally achieved.

Catalytic incinerators have been successfully used for controlling the emissions of odour and VOCs from many industrial processes including animal rendering, plastic processing, coffee roasting, paint spraying, synthetic rubber manufacture and oil refining.

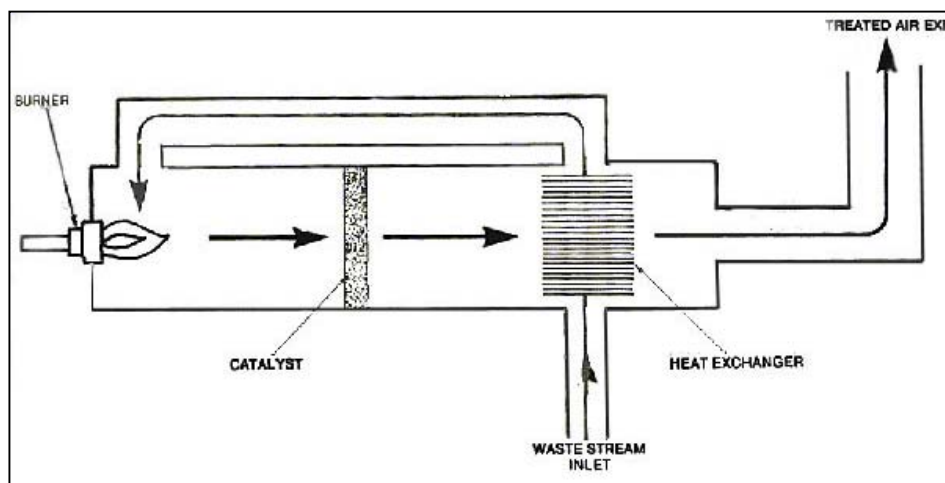
Selection and design considerations

To achieve high odour removal efficiency several factors are of importance:

- choice of catalyst
- properties of the catalyst
- catalyst temperature
- space velocity
- concentration of combustibles and oxygen in the gas stream.

Catalyst

Typical catalyst materials include platinum, palladium, rhodium, copper chromate and oxides of copper, chromium, manganese, nickel and cobalt supported on a base material.

A particular catalyst will be selected to maximise efficiency for a particular gas stream. The majority of catalysts are suitable for exposure to a fairly wide range of materials. Their tolerance to poisoning depends on the nature, concentration and distribution of the catalytically active constituents.

Pre-treatment

Pre-treatment is usually required prior to feeding the odorous gas stream to the incinerator.

- Condensation of water vapour from a wet gas - reduces fuel requirements and corrosion problems.
- Removal of solid and liquid contaminants - may reduce fouling and corrosion. Thorough pre-filtration of contaminated gas streams is essential.
- Preheating to reduce fuel requirements.

Heat recovery

Effluent gas from the catalytic incinerator is used to preheat the incoming gas stream, thus reducing the amount of energy required to heat the catalyst.

There is potential for secondary heat recovery, e.g. to obtain hot water, space heating etc, although temperatures are lower than would be the case for a thermal incinerator.

**Catalytic
incineration
(cont)**

Performance monitoring and maintenance

Gas composition and process parameters can be used as a performance indicator in the same way as for thermal incineration. In addition the temperature of the catalyst and pressure drop across the bed should be routinely monitored to check for fouling and burner problems.

It is important to refer to the relevant Sector-specific Guidance Note or Permit conditions for specific monitoring and associated record-keeping requirements.

Summary of issues associated with the technology

- Spent catalyst will form another waste stream requiring disposal. Replacement is relatively costly, though not required frequently, provided it is treated with care
- Catalysts are prone to poisoning agents (chemicals which chemically combine to the active catalyst material), fouling agents (contaminants which coat the surface, thus interfering with the adsorption/desorption process), activity suppressants (reversible masking agents) and blinding (coating by dust). Pre-treatment of the inlet air stream is very important.
- The cost of pre-treatment and spent catalyst may make catalytic incineration similar in costs to thermal incineration.
- Flame failure can occur if there is a sudden surge of air through the system. To counter this, pressure releases should be done slowly and an audible flame failure alarm should be installed.
- As with thermal incinerators, mechanical breakdown can be a significant problem. Fan breakdown is the most common failure, often precipitated by dust abrasion.

Summary

Table 4.9: Summary of advantages and disadvantages associated with incineration

Incineration	
Thermal - catalytic - boiler plant	
Advantages	Disadvantages
Can handle very high inlet odour levels Very high odour removal efficiencies Heat recovery may be possible Existing boilers can sometimes be adapted for use as thermal incinerators Non-specific; can deal with most odorant species	The volume of air requiring treatment can be a limiting factor in terms of cost, as can the requirement for high temperatures (e.g. for oxidising ammonia), particularly where secondary fuels need to be added Catalysts can be damaged by poisons Further treatment may be needed for dealing with SO ₂ or HCl formed from compounds containing S or Cl High particulate levels in the gas stream can lead to attrition

4.2.9 Other techniques

Odour modification

The term odour modification relates to the discharge of additional volatile substances into the atmosphere in order to change the perceived character or perceived intensity of an odour. This can take the form of:

- **Odour masking** - addition of another odour which is intended to make the original odour more acceptable and/or unrecognisable.
- **Odour counteractant** - describes the phenomenon whereby a mixture of malodourant and counteractant may smell less intense than the sum of the intensities of the unmixed components or the malodourant alone.
- **Neutralisation** - refers to the effect where the interaction between the chemical receptors in the nose and the odorous molecules are modified in some way so as to modify the human response.

The application of odour modifiers can be:

- direct addition to the odorous material at source. Here the modifier must be able to withstand the same conditions as the material being processed. Addition may be made into a duct, or scrubber (adequate time is needed for contact)
- discharge to atmosphere at a distance from the source, between the source and the community, by atomisation and spraying

The **advantages** of odour modification could be thought of as:

- modest capital outlay
- atomiser units are portable, can be rapidly deployed
- highly visible means of being seen to take action over a problem.

The **difficulties** can include:

- the application of odour counteractants can be problematic, as an emission may vary in concentration or nature with time. These variables make it difficult to ensure that unpleasant odours are "blotted out" at all emission levels
- the odour of the modifying agent can itself become a source of annoyance
- in terms of the relationship between perceived intensity and concentration (of malodourant and odour modifier/s), the concentration will decrease down-wind from the source, but the effect on their perceived intensities will not be uniform with the decreasing concentration. This is because for every substance the perceived intensity decreases to different extents for the same decrease in concentration. Other factors such as differing diffusion characteristics of the modifier and the odour itself may cause the odour to separate from the modifying agent at a distance, thus producing two distinctly different odours at different points
- the on-going cost of the modifying agent can be very expensive and maintenance costs can be high as fine spray nozzles can be prone to blockage
- whilst no direct evidence has been found which links the administration of odour modifying agents to ill-health, there is evidence that some of those exposed perceive that there could be an issue. Some of the components such as surfactants can make surfaces slippery
- application should not be considered where the odorous emission carries a risk to health or the odour itself serves as a safety warning.

There are few situations where the addition of another chemical to the air rather than dealing with the problem at source would represent best environmental option from a regulatory viewpoint. Indeed some Sector Guidance Notes forbid the practice. Whilst each case should be examined on its merits and according to the process guidance, the following indicates situations where the use of modifying agents *might* be appropriate.

- As a temporary measure whilst process or plant modifications are made and/or an odour management system is being put into place.
- For dealing with a short term problem, or perhaps to provide *additional* abatement for infrequent odour events (e.g. to cover short-term seasonal variation).
- Where the agent is used in a duct or scrubber such that it is contained and there is no carry over of the agent to the atmosphere where it could undergo subsequent dispersion and have an impact upon receptors.

Water sprays are used with a degree of success on some waste water treatment plants to reduce the escape of odour from open channels and tanks. The potential implications of using treated final effluent in terms of the possibility of creating bacteria-containing aerosols needs to be considered.

**Surfactant-
enhanced
absorption**

Surfactants can be used to enhance the absorption of odorous components of gas streams into water or other reagents, for example in a scrubber. The efficacy will be dependent upon the nature of the gas stream and the plant and should be examined on a case-by-case basis. [Section 4.2.4](#) - absorption - refers to the use of surfactants in enclosed systems. Such products are also available for atomisation and spraying as described in the preceding paragraphs above when many of the same contra-indications for use also apply.

These products are biodegradable in themselves when they fall out to the ground although the nature and biodegradability of the absorbed compounds, particularly those which are toxic or difficult to degrade, will also need to be considered when assessing the impact on the surrounding land. If spraying is undertaken, consideration should also be given to avoiding contact of the fall-out with skin or clothing. Such products can lead to slippery surfaces underfoot.

Condensation

Where an odorous gas stream contains high concentrations of vapour, condensation might be considered for odour reduction. There are various methods for bringing about condensation and they fall broadly into the following categories:

- **Direct contact condensers** - a cooling liquid (at ambient temperature or slightly below) is sprayed into the vapour-laden gas flow. This is the cheapest and simplest method.
- **Indirect contact (surface) condensers** - these are cooled with water or a cooling liquid. Coolant usually circulates in the tubes and vapour condenses on the outer surfaces and drips into a storage tank.
- **Air cooled surface condensers** - air cooled finned tubes are used to cool down the vapour sufficiently for condensation to occur.
- **Pressurised condensers** - gas is compressed before cooling. This is the most efficient condensation method but also the most expensive.

The main problems arising with condensation are high energy requirements, there is no specificity and odorous and non-odorous compounds alike will be condensed and the cost, both capital and operating, tends to be high. Effluent disposal will also need to be considered.

The process of condensation is mainly used as a pre-treatment to other odour abatement technologies. Condensation is a key element in the treatment of discharges from cooking operations.

**Non-thermal
plasma
technology**

Non-thermal plasma technology involves the destruction of gaseous phase contaminants by a plasma generated between two concentric electrodes positioned axially within the ductwork. A pulsed high voltage is periodically applied to these electrodes leading to plasma formation and the appearance of corona streamers. Within the streamers, high energy electrons and UV light produce background gas molecule ionisation and fragmentation which leads to the formation of chemically active radicals. Destruction of the polluting species occurs in the gas stream both as a result of the fragmentation of molecules by direct electron collision within the streamers and through specific chemical reactions mediated by the active radicals. The non-thermal plasma destruction process thus directs the available electrical energy specifically towards creation of the necessary species for destroying pollutants instead of heating the whole bulk of the gas. In a typical reactor the average gas temperature is found to rise by perhaps ten degrees overall.

The advantages of plasma technology include:

- treats all gaseous compound emissions
- outlet gaseous odorous compound concentration can be reduced to a level where the likelihood of odour annoyance will become very small
- end of pipe system, with no disruption to the existing process
- low operating costs
- flexibility of operation. Instantly switched on when required and off when not
- no solid or liquid wastes produced
- the equipment is compact and can be sited adjacent to existing process
- testing has not been able to identify any danger resulting from flammable particulate matter entrained in the gas stream.

The primary difficulty at the time of writing is a lack of field validation. The product is still being evaluated in terms of its commercial viability and it is not possible at this stage to estimate capital, installation and operating costs which will, in any case, be installation specific.

Figure 4.5: Schematic diagram of a plasma unit

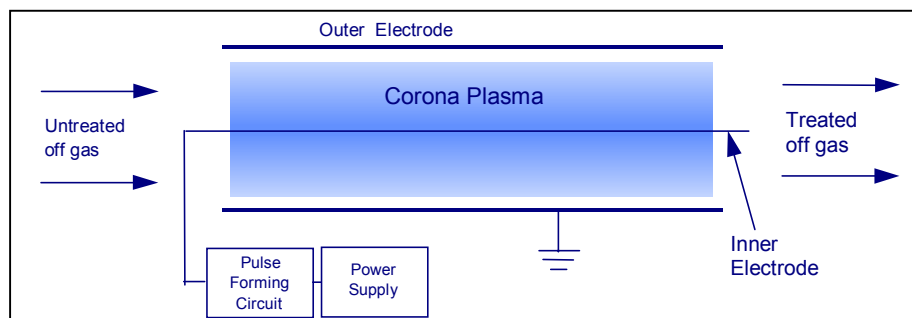

Catalytic iron filters

Catalytic iron filters remove low concentrations of hydrogen sulphide present in air. At 500ppm and above, the media would not be allowed to regenerate so this effectively forms an upper limit for inlet stream concentration, although occasional spikes would be tolerated. Removal efficiencies of 60 to 95% are quoted but each situation should be considered on its own merits.

At present, catalytic iron filters are primarily used by the water industry. Other applications include anaerobic processes in the food industry. Typically a catalytic iron filter is fitted prior to a biofilter or an adsorption unit to minimise peak loads and average out the inlet concentration.

A catalytic iron filter comprises a cylindrical steel vessel with perforated retaining plates at the inlet and outlet and a fixed bed of rusting mild steel packing elements in between. Odorous air passes through the bed where hydrogen sulphide, which is the prime constituent, reacts. For this system to be effective the inlet air stream needs to be reasonably moist with a relative humidity of greater than 75%.

The surface of the packing elements provide sites for the catalytic oxidation of hydrogen sulphide by iron oxide (Fe_2O_3) covering the packing. The reaction requires water to be present and produces an intermediate compound, iron sulphide (Fe_2S_3) before immediately regenerating the Fe_2O_3 from atmospheric oxygen. The intermediate Fe_2S_3 is oxidised to elemental sulphur which gradually forms a film on the packing surface. After a period of time the film formed by the sulphur and the breakdown products of the media (a powder) blocks the air spaces between the packing necessitating replacement of the packing. Another by-product is sulphuric acid which can be removed as an intermediate trickle of dilute solution to a suitable drain. Rusting of the iron can lead to breakdown and cracking of the vessel and crumbling of the packing adds to internal blockages.

A catalytic iron filter is not an odour control technique in itself; it protects and improves the cost effectiveness of the polishing unit (e.g. a biofilter or scrubber).

Ozone and ultra-violet

Ozone is relatively cheap and convenient as well as being a powerful oxidant, reacting with a wide range of compounds (primarily alkenes, amines and organic sulphur compounds) to produce mainly oxides and oxygen, which are non odorous.

Ozone has number of roles in odour control:

- as a gas phase reactant - for "in stack" odour control, i.e. direct injection of oxidants into the discharge stack or ductwork. This technique has been widely used in the deodorisation of gases from sewage treatment plants. Ozone can also be used as a final "polishing" treatment for gases exhausted from a scrubber
- as a liquid phase oxidant to oxidise water-insoluble odorants into water-soluble products which can be removed by subsequent water scrubbing
- to control the growth of microbial populations causing decay odours
- in conjunction with activated carbon - there is some evidence for an enhanced adsorptive effect when ozone is added to the gas stream to be treated prior to passage through carbon filters (Reference 15).

**Ozone and ultra-violet
(cont)**

Injection of UV excited radicals into a gas stream follows similar principles for the abatement of odorous compounds to those of ozone. This method is known as Advanced Electron Ray Oxidation technology and uses catalysts to create the chemically active radicals in isolation from the gas stream and then injects them into the gas flow, where rapid oxidation of organic compounds in the off gas takes place. This system has the advantage that the catalysts used to generate the active radicals, which are supplied via a completely separate air feed, are protected from contamination by the dirty gas. Such a system has been used in many applications in the animal feed and similar industries, where high odour concentrations are typical. Efficiency varies from application to application.

Ozone can be generated on site fairly economically; the most practical means is by way of a glass tube dielectric around which is produced a corona discharge. The discharge converts a proportion of the oxygen in the feed air into ozone. Such generators are available as complete packages.

There are however a number of disadvantages which have limited the widespread use of ozone.

- Ozone is highly toxic, as well as corrosive, and has a pungent odour. Considerable care must be taken under conditions of fluctuating odour levels to control the dosage in order to prevent discharge of a high, and potentially dangerous residual concentration of unreacted ozone, (abatement is generally by adsorption).
- Ozone is unstable, requiring the facility for on-site generation.
- The rate of oxidation varies from compound to compound and in addition the rate of oxidation is highly dependent on temperature. At ambient temperature the half-lives for the oxidation of most odorants in an ozone/air mixture are of the order of seconds or minutes, requiring large holding chambers to obtain the necessary reduction in odorant concentration.
- Ozone is a selective oxidant and while it reacts (given some time) with alkenes, amines and organic sulphur compounds and, less readily with alcohols and aldehydes, it is rather unreactive in short exposures towards ketones, carboxylic acids and esters. Given the complex mixtures of odorants encountered in many odour problems, the selective nature of destructive gas-phase oxidation with ozone is a further hindrance to its widespread application.

Overall, application has been rather limited. It has been most widely used for removing highly reducing compounds such as hydrogen sulphide. Some of the water companies have adopted this technique and it has also been piloted by the food flavouring industry. There has also been some use of ozone as an "in duct" reactant for removing cooking odours, for example in commercial kitchens/food processing.

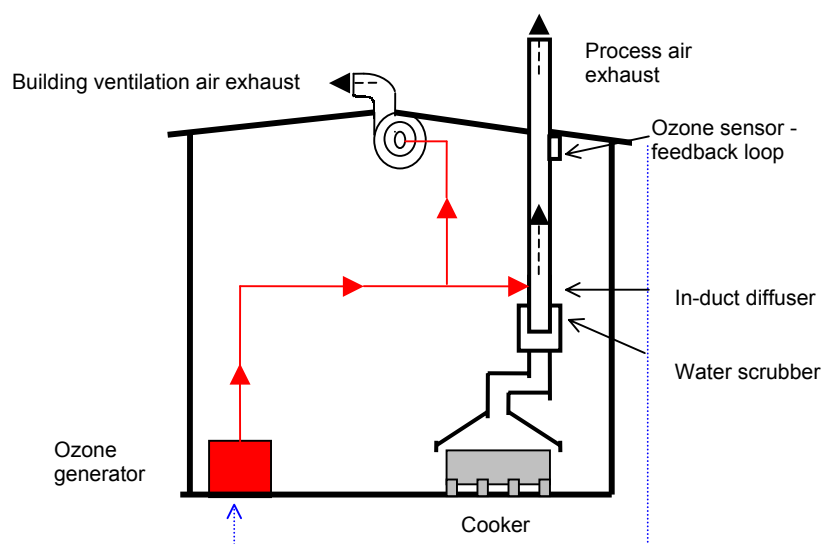

Figure 4.6: Ozone exhaust odour control system

REFERENCES

1. IPPC H4: Horizontal Guidance for Odour. Part 1: Regulation and Permitting. Published for consultation as a working draft. October 2002.
2. Assessment of community response to odorous emissions – R&D Technical Report P4-095, undertaken for the Environment Agency by OdourNet UK Ltd, publication due Autumn 2002
3. Odour Control – A Concise Guide, Warren Spring Laboratory for DoE, 1980 ISBN 0 85624 2144
4. Odour Measurement and Control – An Update, Woodfield & Hall (Editors), AEA Technology for DoE, 1994. ISBN 0 85624 8258
5. IPPC Guidance Note: “Odour management at intensive livestock installations”, Environment Agency. Likely to be published for consultation in 2003.
6. Application of contour mapping of hydrogen sulphide levels to control odour at sewage treatment works, Foundation for Water Research, Report FR0060, February 1990.
7. Determination of the Best Available Techniques for Control of Odour – R&D Technical Report P4-079/2, AEA Technology on behalf of the Environment Agency, publication due Autumn 2002.
8. IPPC Guidance Note H1 – Environmental Assessment and Appraisal of BAT. Environment Agency, 2002.
9. Internal Guidance for the Regulation of Odour at Waste Management Facilities under the Waste Management Licensing Regulations, July 2002, Version 3
10. Schauburger and Piringer (1997) “Guidelines to assess the protection distance to avoid annoyance by odour sensation caused by livestock husbandry” Proceedings of the Fifth International Environmental Symposium, May 29 - 31, pp170-178.
11. Air quality - Determination of odour concentration by dynamic olfactometry. CEN/TC264/WG2/N222/e. The most recent draft version is dated 2001. The final version is expected in March 2003.
12. BS 3405 British Standard Method for “ Measurement of particulate emissions including grit and dust (simplified method)” (1983), BSI.
13. Wijnen H (1986) Air quality standards on odours in the Netherlands. VDI Berichte 561: 365-385
14. Gibson, Swanell, Woodfield, Van Groenestijn, van Kassell, Hesselink, Hecht – “The abatement of volatile organic compounds (VOCs) by biological methods: A protocol outlining their relationship to conventional techniques and their applications to uncontrolled sources” 1993, EC STEP project 900431
15. Dorling, T.A. (1978) Activated Carbon in Odour Control. Warren Spring Laboratory Report, LR 293 (AP)
16. VDI standards can be obtained from VDI, Beuth Verlag GmbH, 10772 Berlin. German/English copies are available. The VDI standards mentioned in this document are:
 - VDI 3883 Part 1 Effects and Assessment of Odours; measurement of nuisance through interview; questionnaire technique.
 - VDI 3883 Part 2 Effects and Assessment of Odours: determination of annoyance parameters by questioning. Repeated brief questioning of neighbour panellists.
 - VDI 3940 Determination of odorants in ambient air by field inspection
17. HMIP Technical Guidance Note D1 “Dispersion – Guidelines on discharge stack heights for polluting emissions”, HMSO, June 1993
18. HMIP Technical Guidance Note A3 “Abatement - pollution abatement technology for particulate and trace gas removal”, HMSO, April 1994.

Glossary of odour-related terms

Acceptability criterion	A level of exposure (of sensitive receptors) which, according to current understanding, is acceptable to the majority of the population. These criteria are expressed in terms of a number of odour units as a percentile of a year of hourly means and are based upon dose effect studies undertaken around a number of odour-emitting industry types. The term “odour exposure criterion” has the same meaning.
Analytical assessment	An assessment of an odorous sample using instrumentation to provide a information on the concentration and possibly provide identification of the chemical species present. Compare with “sensory” assessment.
Anosmia:	Lack of sensitivity to olfactory stimuli – unable to detect odours at all (compare with hyposmia)
Area source	A surface-emitting source, which can be solid (for example the spreading of wastes, material stockpiles, surface of a biofilter) or liquid (storage lagoons, effluent treatment plant).
Detection threshold	The point at which an increasing concentration of an odour sample becomes strong enough to produce a first sensation of odour in 50% of the people to whom the sample is presented. This is a laboratory-based test and should be conducted according to the relevant CEN standard. The odour concentration at the detection threshold is one odour unit.
Exposure	Concentration x duration x frequency of the odour to which a receptor is exposed.
Fugitive releases	Unintentional emissions from eg flanges, valves, doors, windows – that is, points which are not designated or intended as release points.
Hedonic tone	A judgement of the relative pleasantness or unpleasantness of an odour made by assessors in an odour panel. A methodology is described in VDI 2882. (Compare with “offensiveness”). Odours which are more offensive will have a negative hedonic score whilst less offensive will tend towards a positive score. Hedonic scores are listed in Part 1 of this Guidance Note.
Hyposmia	Partial inability to detect odours (compare with anosmia)
Odour concentration	The amount of odour present in a cubic metre of sample gas at standard conditions. The odour concentration is measured in European odour units ($ou_E m^{-3}$). The odour concentration at the detection threshold is defined to be $1 ou_E m^{-3}$. If an odour sample has been diluted in an olfactometer by a factor of 10,000 to reach the detection threshold, then the concentration of the original sample is 10,000 odour units.
Odour unit	The amount of odorant(s) that, when evaporated into 1 cubic metre of neutral gas at standard conditions, elicits a physiological response from a panel (detection threshold) equivalent to that elicited by one European Reference Odour Mass (EROM), evaporated in one cubic metre of neutral gas at standard conditions
Offensiveness	An expression of the degree of unpleasantness of one odour relative to another. The perceived offensiveness of an odour will vary between individuals as a result of both physical and psychosocial differences, but in a population a relatively consistent response on the relative offensiveness of different odours is returned.
Olfactometer	Apparatus in which a sample of odorous gas is diluted with neutral gas in a defined way and presented to a odour panel under reproducible conditions.
Panel member	An assessor who is qualified to judge samples of odorous gas, using olfactometry within the scope of the CEN Olfactometry standard (Reference 11). An assessor has to fall within defined limits of sensitivity as set out in the CEN standard.
Point source	An intentional point of release such as a vent or chimney, where it may be possible to obtain a sample in order to quantify the concentration and determine the mass release rate
ppb	Parts per billion
ppm	Parts per million

GLOSSARY

Recognition threshold	The odour concentration which has the probability of 0.5 of being <u>recognised</u> under the conditions of the test. The recognition threshold is generally a higher concentration than the detection threshold. It is generally two or three odour units in a laboratory setting but may be higher than this outside the lab.
Sample	The odorous gas sample which is assumed to be representative of the gas mass or gas flow under investigation, and which is examined to determine the odour concentration, to characterise the odour or to identify constituent compounds.
Sensitive receptor	People who are exposed to odour released from a given source, or have the potential to be exposed. Unlike other pollutants, odour at environmental exposure levels is not considered in terms of possible detrimental effects on animals and plants.
Sensory	Relating to the human response to a particular stimulus (in this case, odour). Compare with “analytical” methods of assessment.

APPENDIX 1 - Comparison of main odour abatement technologies

The following provides a comparison of the main abatement techniques across a number of different aspects. It is intended to be indicative only, as the effectiveness of each will depend upon the nature of the gas stream and the suitability of the technology selected to the particular application.

Table A1.1: Summary and comparison of abatement technologies
(Continued overleaf)

	Adsorption	Incineration		Wet Scrubbers	Biological treatment	
		Thermal	Catalytic		Biofiltration	Bioscrubbers
Application	VOC & odour removal.	VOCs Odours		VOCs Odours Acid gases	Odours Some VOCs	Odours Some VOCs
Input stream	Low concentrations, low flow. Not suitable for particulate or high moisture content	High concentration, low to medium flow, but some systems can cope with quite high flow. Particulate can cause attrition or bed failure/blockage.		Med-low concentration, high flow rate. Packed beds are not suitable for particle removal, but spray and plate absorbers can remove some particulate.	Low concentration, high volume. Slow to adapt so not suited to fluctuating concentrations or batch processing.	
Efficiency (%)	>90% but can be higher with successive stages in series	Can be >99% but there is often a residual combustion odour	95% or more.	90% with water, but can be greater with appropriate chemical reagents in one or more stages, or catalytic scrubbing.	Soil filters up to 99% in exceptional circumstances. Peat/heather – up to 95% if properly maintained. Often limited by ambient conditions.	Up to 99% if well maintained and operated.
Relative cost: Installation Operating	Low - Low - Medium (but depends on number of stages) Regeneration costs also have to be considered.	High Med - High	High High Catalyst is expensive	Medium Medium-high (Depends on number of stages)	Low Low	Medium Low - medium
Maintenance Requirements	Low maintenance needs but on-site regeneration adds to complexity	High	High	Generally high. Some reactants are corrosive or produce salts which cause blockages	Daily maintenance but not complex - often neglected	Low - medium
Energy use	Low – depends on total pressure drop	High May be sufficient calorific value to allow use of gas stream as a supplemental fuel. Potential for heat recovery		Medium - Energy required to move gas and reactant. May be two or more stages	Relatively low	Low
Water use	0	0	0	If water is used as a reactant, particularly once through, usage can be relatively high.	Regular irrigation required.	Usage can be high
Raw materials usage	Low if regenerated	Fuel to maintain temp	Fuel to maintain temp	High usage of reactants, careful control is needed.		

APPENDIX 1

	Adsorption	Incineration		Wet Scrubbers	Biological treatment	
		Thermal	Catalytic		Biofiltration	Bioscrubbers
Wastes generated	Saturated carbon, unless regenerated (but this produces a high concentration gas stream which will need to be treated)	Releases to air. NO _x , CO, organic compounds S or Cl will produce SO ₂ and HCl		May produce sludges and exhausted reactants which are difficult to handle. Large quantities of effluent can be generated where inlet moisture levels are high	Bed will need replacement every few years - not a problem waste	Possibility of odorous and biologically active waste. May be some carry-over of organisms
Comments	Good for small scale operations using disposable cartridges but these can be expensive if used on a large scale.	Care needed to avoid poisoning of catalyst. There may be potential to burn gas stream in an existing boiler or furnace. Non-specific - can deal with most odorant species although some (ammonia) may need higher temperatures.		Carry-over of reaction products can lead to new odour complaints. Catalytic scrubbing might be an alternative to a multi-stage scrubber.	Large footprint. A back-up or some other contingency is required in case of poisoning	Much smaller footprint than biofilters. Can be poisoned. A back-up or some other contingency is required in case of poisoning

See [Figure 4.2](#) for a comparison of the suitability of the main techniques for different combinations of flowrate and concentration.

Relative costs and potential for application to different gas streams

The following is indicative only, and necessarily ignores detailed breakdown of gas composition and assumes suitability for purpose. It is intended to be a very broad comparison of capital costs by using five generic flow/concentration scenarios.

Table A1.2: Description of the five generic emission scenarios considered

Description of odour emission scenario	Odour concentration (ou/m ³)	Flowrate (m ³ /hr)	Some example industries
1. High odour concentration, high flow	100000	10000	Vegetable drying
2. Low odour concentration, high flow	5000	10000	Animal feed plant
3. Medium odour concentration, medium flow	50000	4500	
4. High odour concentration, low flow	100000	1000	Rendering
5. Low concentration, low flow	5000	1000	

Table A1.3: Comparison of capital costs

	Incineration	Single stage scrubber	2 stage scrubber	3 stage scrubber	Acid gas scrubber	Base gas scrubber	Biofilter	Carbon adsorption
Emission scenario								
1	HIGH (except if using boiler)							
2		LOW - MED	MEDIUM		LOW - MED	LOW - MED	LOW	
3		LOW - MED	MEDIUM	HIGH (plus high reagent cost)	LOW - MED	LOW - MED		
4	HIGH (except if using boiler)							
5								LOW (cost of carbon can be high)

 = Relative capital cost, sizing etc being equal. Periodic major refurbishment requirements have not been considered.

Operating costs

In the majority of cases electricity is the largest operating cost, except where high quantities of reagent are used in a 3 stage scrubber, or carbon replacement where concentration is high or flow is medium. However periodic major replacement costs should also be considered as part of the operating cost (an indication of the lifetime of various components, or corrosion expectations etc are covered in outline in the main text).

The number of scrubbing stages required will depend upon the composition of the gas stream, and the number of different reagents required. The above is illustrative only in terms of more stages = higher cost.

Scrubbers, biofilters or adsorbers might be used as a polishing stage.

For the purposes of costing (both capital and operating) flowrate is more important than odour concentration because:

- the greater the flow, the larger the odour control system, i.e. bigger ducting, bigger fans and other hardware
- the greater the flow, the greater the operating cost, i.e. more powerful fans are required and hence the energy usage is greater, and more chemicals and other consumables are required.

See also [Figure 4.2](#).